



## Product datasheet

# Metal Matrix Composite (MMC) Concaves

The efficiency and performance of gyratory crushers are heavily reliant on the design and material properties of their concaves, as well as their interaction with the other key components. FLS is an industry leader in crushing with many successful and productive installations. Now offering MMC technology, we continue to innovation towards improving your crusher's productivity and efficiency.

### FLS is adding to the concave material options with MMC

Metal Matrix Composite (MMC) concaves are formed by incorporating hard particles, like carbides, into a more pliable casted base material, such as steel alloys, ensuring a full material bond between the inlays and the base material. Finding an optimal combination through R&D and field testing, the MMC concaves are increasing wear life, decreasing downtime and delivering sustainability benefits to crushing operations.

### Benefits

- Improve concave lifetime by up to 3x
- Reduce total cost of ownership by up to 50%
- Increase overall productivity by improving crusher availability
- Minimize scrap, CO2 emissions and environmental impact by reducing number of change outs required

# Enabling maximum crushing efficiency and sustainability

## Improving availability and uptime

MMC concaves are designed and has been tested for extreme wear and impact resistance. In field tests, the customer had seen up to a 300% increase in wear life compared to concaves using standard material composition. This results in decreasing downtime associated with shutdowns, helping to increase the crusher availability.

Less shutdowns will also decrease maintenance related risk, creating an overall safer work environment around the crusher.

## Sustainable operations

Multiple sustainability benefits also have been discovered as a result from this innovative solution.

Waste scrap is minimized due to the longer lifetime of the concaves and less change outs required. Less concaves are being produced and reducing the CO2 emissions associated with production and less trucks required to transport concaves. Energy efficiency benefits also result due to the concaves inlay keeping original shape for longer, the crusher can run at the optimal level for longer. Hence, leading to maximum power consumption efficiency.

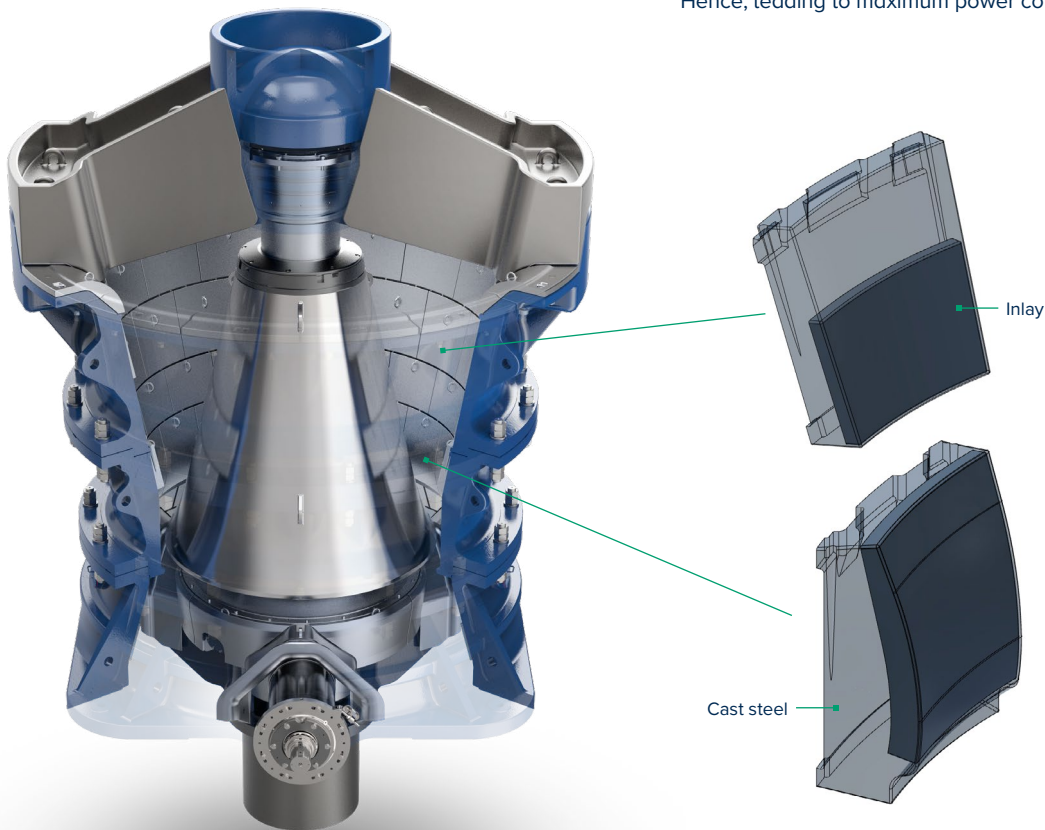

Learn more about  
**MMC concaves**



**FLSmidth A/S**  
2500 Valby  
Denmark  
Tel. +45 3618 1000  
info@flsmidth.com

[www.flsmidth.com](http://www.flsmidth.com)

Copyright © 2024 FLSmidth A/S. All Rights Reserved. FLSmidth and FLS are registered trademarks of FLSmidth A/S. This brochure makes no offers, representations or warranties of any kind (express or implied), and information and data contained in this brochure are for general reference only and may change at any time. FLSmidth does not guarantee or make any representation regarding the use or the results of the information or the data provided in the brochure in terms of its correctness, accuracy, reliability or otherwise, and shall not be liable for any loss or damage of any kind incurred as a result of the use of the information or data provided in the brochure.