

# KREBS® Pumps, Cyclones and Valves for the Aggregate Industry

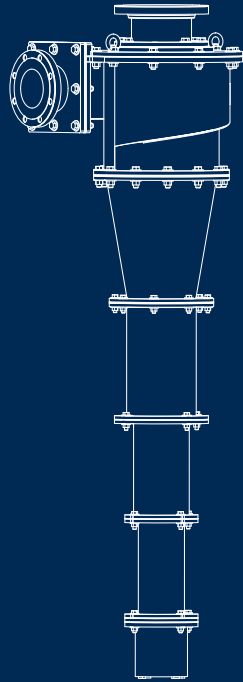

**FLS**



## CYCLONES

---

gMAX®	4-5
CycloStack™	6
CycloWash™	7

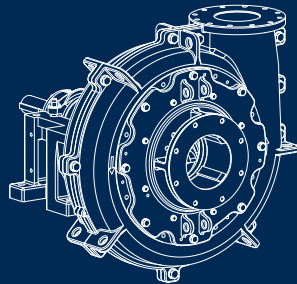

## PUMPS

---

slurryMAX™	8-9
gravelMAX™	10-11
millMAX™-e	12-13



## VALVES

---

KREBS® knife gate	14
-------------------	----

# KREBS® products for the aggregate industry

KREBS® products lead the global industry for high efficiency pumps and improved cyclone performance.

We have helped advance the productivity of aggregates operations and provided innovations for greater production, efficiency and reliability. We continue to improve our designs and materials to provide long-lasting components.

## KREBS® hydrocyclones

Our hydrocyclones provide you with the separation performance you need using leading technology.

## KREBS® pumps

Our pumps provide increased wear life with online wear adjustments along with higher efficiencies resulting in power and cost savings.

## KREBS® knife gate valves

Our knife gate valves provide provide high performance. Our field-replaceable wear sleeves reduce downtime, keeping the valve in service by allowing faster maintenance.

## KREBS® Cyclone accessories

Our CycloStack™ and CycloWash™ options provide solutions to improve underflow sand quality.





# KREBS® gMAX® Optimum cyclone performance

## Sand or fines recovery applications

In an aggregate plant, cyclones are most commonly used to recover saleable sand from a waste stream. Recovering sand from the classifier or sand screw overflow stream can add a significant amount of otherwise wasted material to the product.

In a typical sand recovery system, the sand screw overflow reports to a sump. A pump feeds the overflow to an elastomer-lined cyclone. The cyclone underflow contains the sand. It can be returned to the sand screw about 3/4 of the way up the screw, or stacked as a fine sand product. The cyclone overflow typically reports to the waste pond.

## gMAX technology used in the following aggregate applications

- Product Classification
- Dewater/Deslime
- Product Recovery
- Fines Recovery

## gMAX® technology outperforms all the others

Optimum cyclone performance relies on minimising turbulence while maximising tangential velocity. The gMAX® cyclone focuses on these two important factors, significantly advancing cyclone performance. To achieve these two design criteria, the gMAX incorporates performance-enhancing improvements to the inlet head, cylinder section, cones and apex.

### gMAX® Benefits

- Finer, sharper particle separations at high capacities
- Fewer cyclones needed for optimal performance
- Pre-classification and increased efficiency
- Less turbulence
- Less wear compared to competitors' designs
- Easy maintenance
- Works with existing installations





# gMAX<sup>®</sup> Technology Innovative cyclone design

## Inlet head design

The innovative gMAX<sup>®</sup> inlet design provides finer and sharper particle separation at high capacities. Our commitment to continuous improvement in separation technology for our mining and industrial customers is why we are the world leader in cyclones.

The outer wall involute design entrance pre-classifies the feed solids prior to entering the main body of the cyclone. The inlet head of the gMAX also includes an improved vortex finder and top cover plate liner design.

These improvements result in reduced misplacement of material to the overflow and dramatically increased wear life. By using premium ceramics in the lower section of the cyclone, we've boosted overall wear life, greatly increasing the intervals between complete cyclone rebuilds.

## Paint wear test: gMAX vs. outer wall tangential

To validate the reduced turbulence and wear characteristics predicted using computational fluid dynamics (CFD) on the gMAX inlet head design, layers of paint in different colors were applied to the gMAX inlet head liner (left insert) and to a competitor's outer wall tangential inlet head liner (right insert). The components were assembled onto cyclones and slurry was pumped through them in our lab. The resulting wear patterns show a dramatic reduction and wear as a result of the improved gMAX geometry.

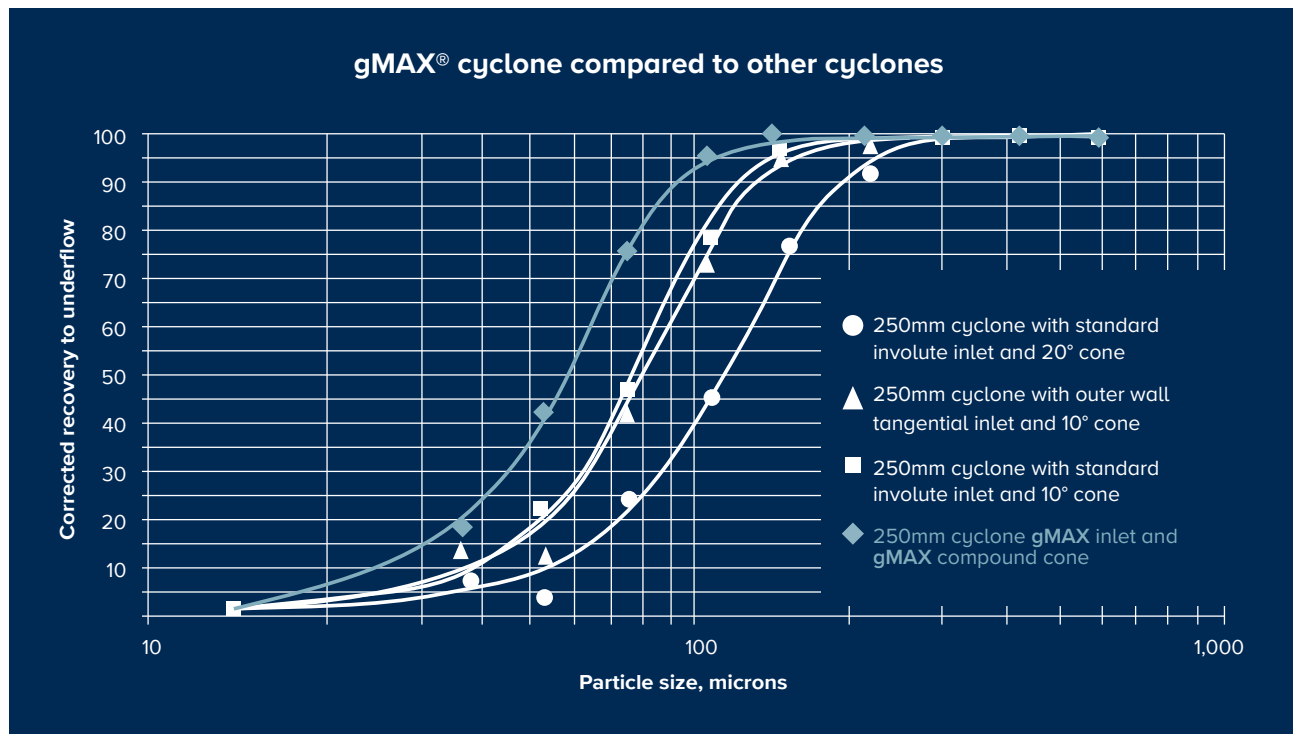

# CycloStack™

## Dewatering solutions

### Dewatering applications

Our CycloStack™ attaches to the bottom of a standard cyclone to minimise the moisture content in the underflow. The attachment automatically controls the dewatering and discharge concentration of the cyclone underflow, allowing direct discharge of the underflow onto a conveyor belt or into a pile. This occurs even with fluctuating feed conditions.

### CycloStack features

The CycloStack has a urethane flap that opens to discharge solids while retaining water in the cyclone. The vacuum caused by the siphon in the overflow pipe closes the CycloStack when there are no solids present.

### Performance

The device eliminates plugging in the apex because it constantly adjusts the apex diameter. It is a low-cost important addition that allows attention-free operation.



Solids discharging through CycloStack

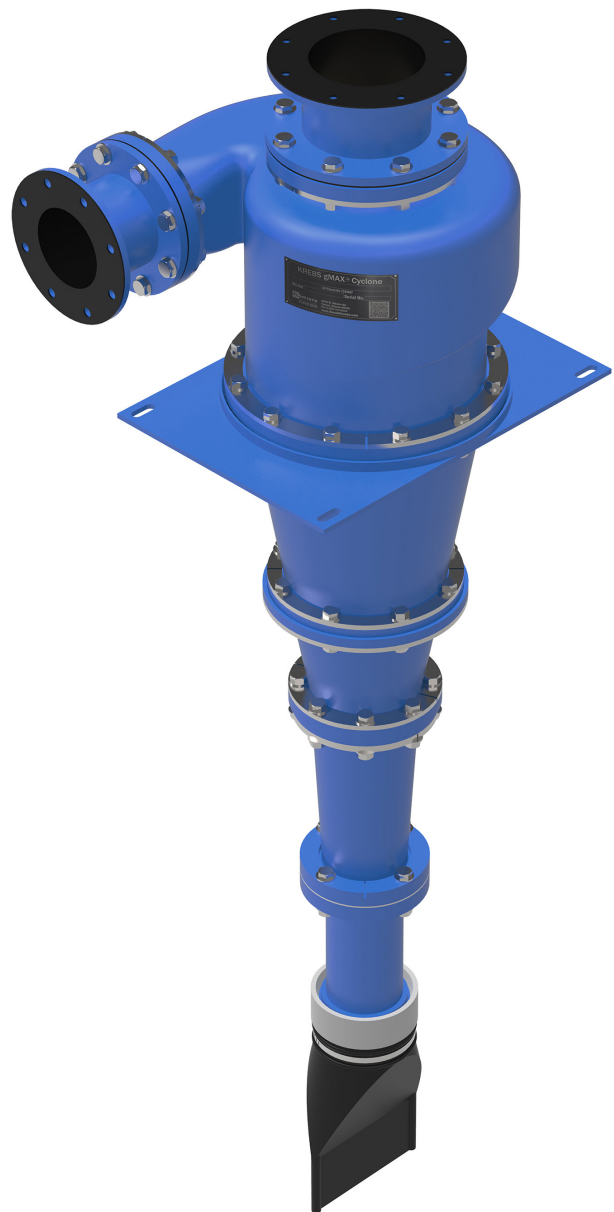

CycloStack boot installed on apex of cyclone to control the moisture in the coarse sand discharge

# CycloWash™

## Second stage classification

### Elutriation

Our CycloWash™ is a patented elutriation device that deslimes solids to reduce operating costs.

### Principle of operation

Normally, classification happens in the upper portion of the cyclone. This classification is typically the only stage of desliming.

The CycloWash injects water into the partially thickened pulp in the lower section of the cyclone. It creates a second stage of classification because displaced water with fines joins the cyclone overflow. The remaining coarse solids are thickened more by this process and discharged through the apex orifice.

The CycloWash can be installed on single cyclones or manifold systems. To maximise both desliming and dewatering, the CycloWash and CycloStack may be used in combination.

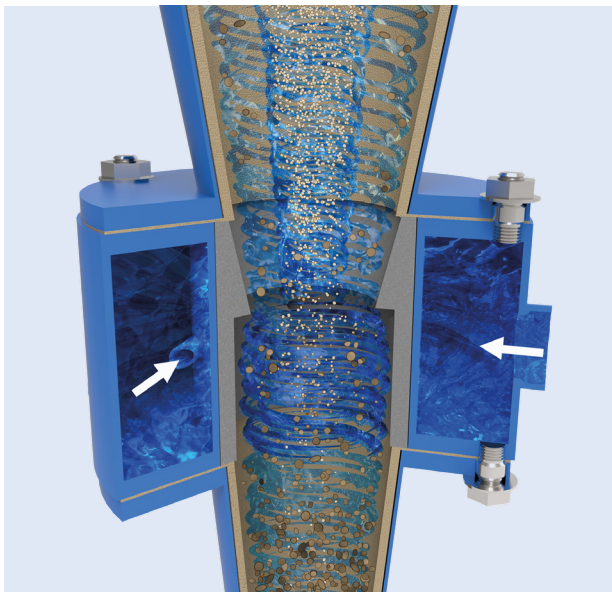

Water is injected into cone of cyclone adding second classification stage

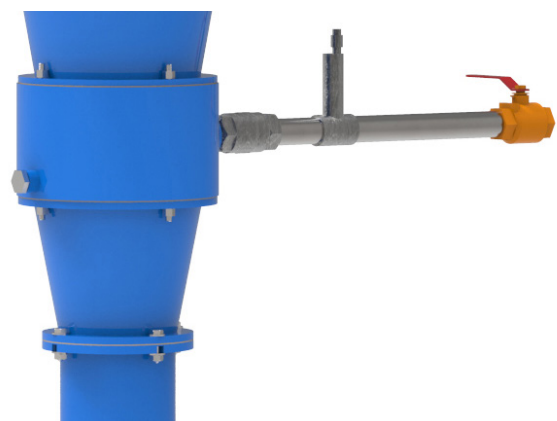

CycloWash installed on lower section of cyclone



# slurryMAX™ Heavy duty split case design

You asked for a split-case pump with longer wear life and better efficiency, which can easily and safely be maintained throughout your plants. That's why we designed our newest KREBS® offering - the slurryMAX.

## Superior Design

This heavy duty pump has a split casing design for easier maintenance and better efficiency. With an externally-adjustable wear ring to also give you suction side sealing, there is not a slurry pump on the market that works harder or longer between maintenance shutdowns.

## Your safety is our priority

This pump has a volute liner with an integrated backliner that bolts safely to the outer drive side casing. Not only does this make maintenance easier—it also keeps you safer by eliminating some of the most problematic pinch points.

## Increased operation efficiency

Our slurryMAX increases your operation efficiency by 10–15% by solving both the grinding and recirculation problems within your pump. With lower power consumption comes a lower cost per ton.

We provide centrifugal seal options with increased performance due to the large diameter expeller and oversized vanes. With this option, many of our customers have been pleasantly surprised that they can eliminate gland water requirements when they use our pump.



## Benefits

- Even and predictable wear life due to the elimination of grinding in the pump
- Constant hydraulic performance because no longer recirculate your feed
- Significant energy savings because of eliminated grinding and recirculation
- Highly effective centrifugal seal with large diameter expeller and oversized vanes
- Eliminate gland water requirements to help yourself and the environment

# Multiple material options - Liners, impeller and wear ring available in gum rubber, metal and polyurethane

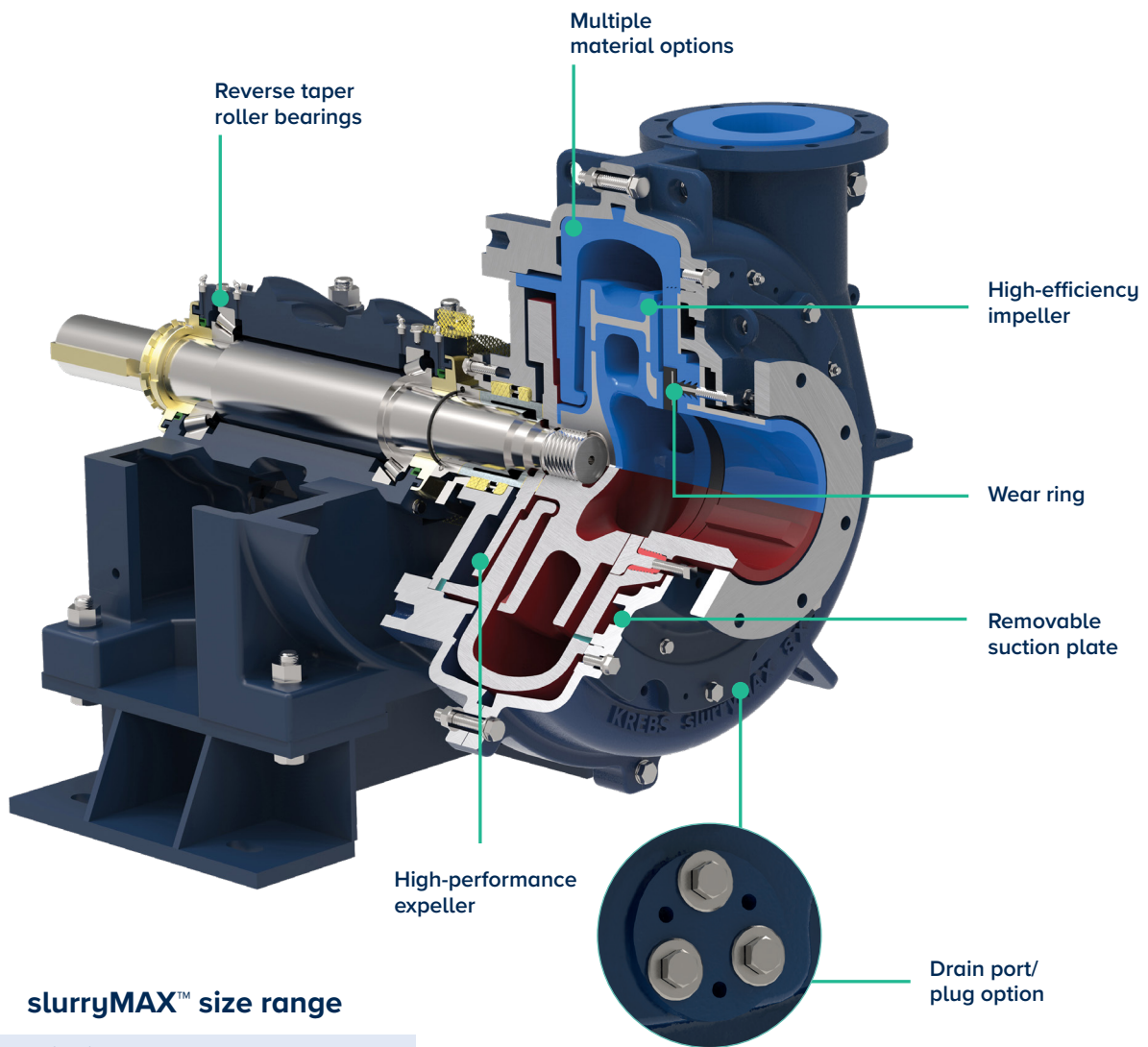

## slurryMAX™ size range

U.S. units (in)	Metric units (mm)
3 x 2	80
4 x 3	100
6 x 4	150
8 x 6	200
10 x 8	250
12 x 10	300

# gravelMAX™

## Large-solids slurry pump

Our innovative hydraulic design makes the gravelMAX the perfect solution for optimised passing size, efficiency and wear life.

### Slurry applications

Our gravelMAX™ pump is designed for slurries with large solids. They are ideal for dredging and in a transfer applications.

### Superior Design

Anyone who has previously dealt with open impellers or extremely oversized pumps in an attempt to transfer large solids will appreciate the difference made by a pump that is specifically designed for the job.

Our gravelMAX has wide diameter impellers and large cutwater clearances to optimise passing size. We use our patented suction-side sealing system wear ring to eliminate grinding the large solids that otherwise occurs in the pump. These specialised features get you greater efficiency and longer wear life.

### Increased operation efficiency

The wear parts for our unique gravelMAX pump last 50–100% longer than parts for conventional slurry pumps. Our customers also report a 10–20% decrease in power consumption after they install our pump for their large solid application. These savings equate to a lower cost per ton than you can get from other slurry pumps on the market.

Ending suction-side recirculation does more than eliminate grinding within the pump. It also increases the vacuum that our pump is capable of pulling, which makes it able to handle more.



### Benefits

- Pump large and abrasive solids
- Maintain cyclone pressure longer
- Reduce the cost per ton
- Adjust pump while running
- Longer service life
- More robust wet-end components



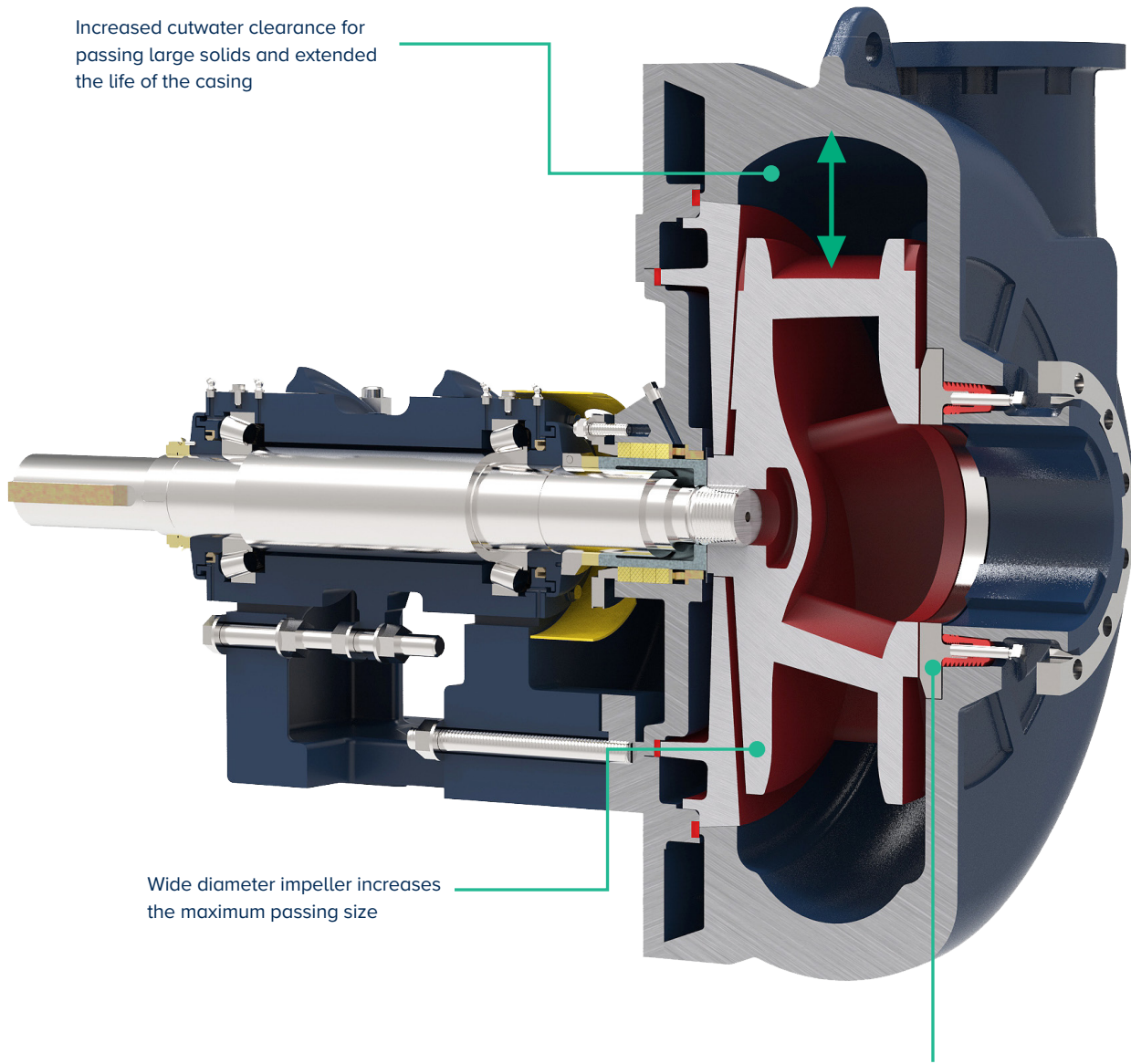

Increased cutwater clearance for passing large solids and extended the life of the casing

Wide diameter impeller increases the maximum passing size

**Adjustable Wear Ring**

Closes the suction-side impeller clearance during operation to reduce recirculation and maintain hydraulic performance

**gravelMAX™ size range**

U.S. units (in)	Metric units (mm)
6 x 4	150
8 x 6	200
10 x 8	250
12 x 10	300
14 x 12	350

# millMAX-e™ Revolutionizing slurry pumping efficiency

Don't be fooled by the compact design of our millMAX-e™. Our smaller pump that packs a punch!

Our millMAX-e pump is the most efficient slurry pump in its class. Sites that are looking for efficiency in an application that requires high speeds and high power should look no further.

The unique level of efficiency that you get with this pump allows us to couple it with a smaller motor than is needed for other pumps. This saves you space, power and money.

As with our other pumps, our proprietary wear ring will reduce recirculation that extends the life of your impeller, so you can go longer between maintenance shutdowns.

## millMAX™-e Benefits

- Reduced power consumption
- Even and predictable wear life
- Constant hydraulic performance
- Compact design to optimise space utilisation





The wide clearance between the impeller and suction side eliminates the mechanical grinding of solids.

The adjusting screw lock nut compresses the wear ring carrier to provide a seal to atmosphere and lock the jacking screw in place.

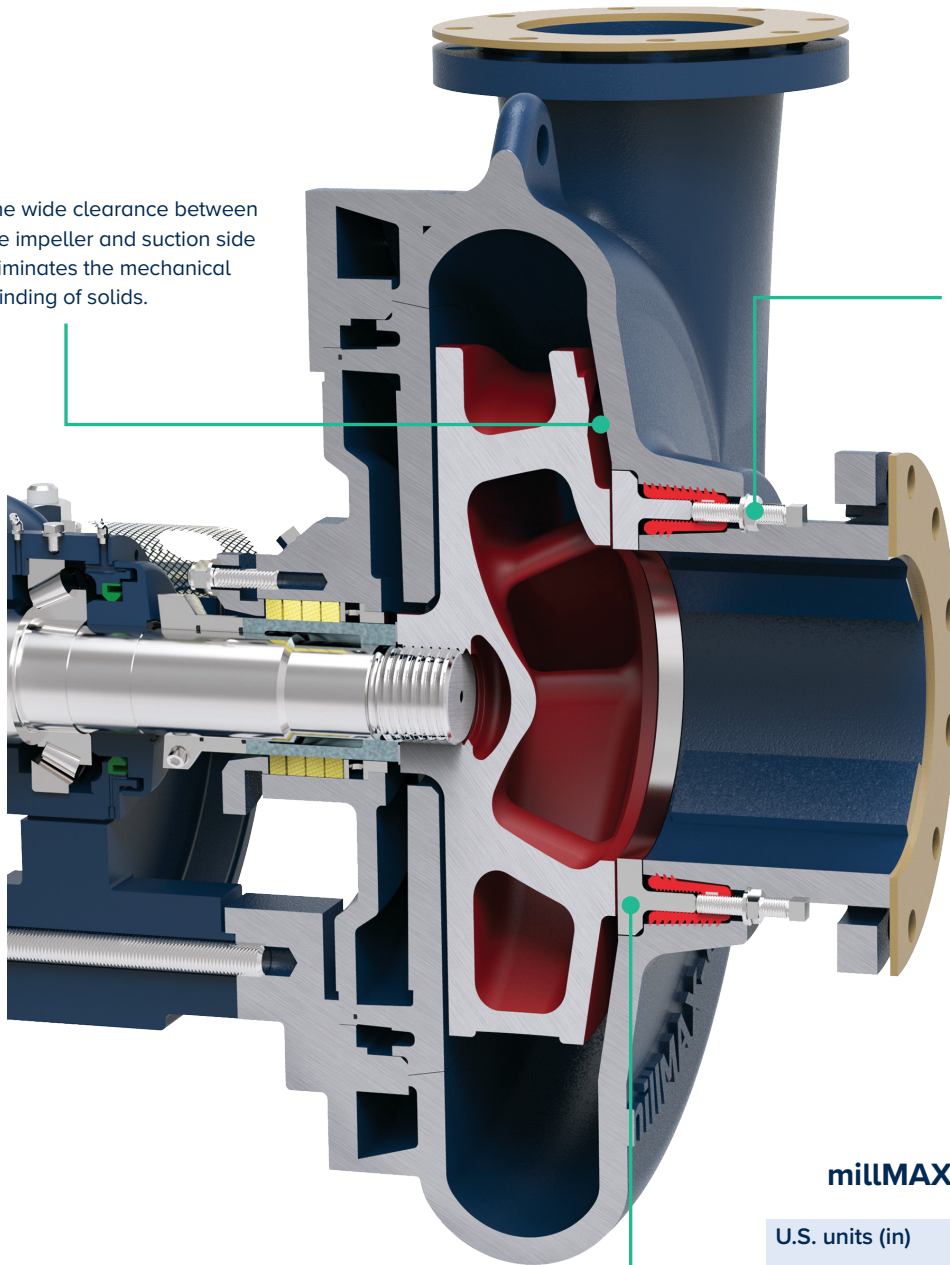

The externally adjustable wear ring closes the suction-side impeller clearance during operation to reduce recirculation and maintain hydraulic performance.

### millMAX-e™ size range

U.S. units (in)	Metric units (mm)
2 x 1.5	50
3 x 2	80
4 x 3	100
6 x 4	150
8 x 6	200
10 x 8	250
12 x 10	300
14 x 12	350
16 x 14	400



# KREBS® slurry knife gate valves for aggregate applications

KREBS® knife gate valves are heavy duty premium valve designed for harsh service.

## Designed for productivity

Our KREBS® knife gate valves are built to handle brutal conditions. This true bi-directional knife gate slurry valve is self-flushing and has a full port flow.

Replaceable wear sleeves protect the valve from even the most abrasive slurries. They also extend past the body to provide a better seal and eliminate downstream leakage.

We understand that your processes can change and valves can be needed for different purposes. We make your life easier by selling interchangeable actuator kits.

The TG Next Generation valve offers many upgraded design features for even better performance and easier maintenance.

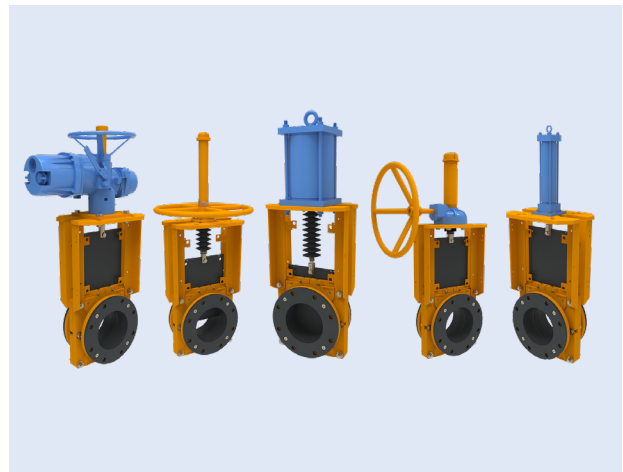

## KREBS® Slurry Knife Gate ADVANTAGE!

- Proven quality materials and reliability
- Field-replaceable wear sleeves to reduce downtime
- Self-flushing eliminates the need for a packing gland
- Interchangeable actuators across TG series
- Heavy duty wear sleeves provide bi-directional flow and 100% bubble-tight seal with zero downstream leakage
- Fully lined valves ensure all metal components remain clear of process material
- Material is ejected out of the bottom during actuation, ensuring full gate closure and providing a reliable seal

## Site Support

Once the pump is installed, our team of site support engineers closely monitors the pump's operation on-site, ensuring that it is consistently operating within the designated parameters. This is particularly important as aggregate plants are not static operations: they develop and change over time, which can result in pumps operating outside of their BEP zone, with negative impacts on performance, energy consumption, and wear rates.

A site support engineer will note any changes to the operating conditions and be able to recommend upgrades or changes to practice that will ensure the pump continues to deliver the best-possible performance. They can also offer training to customer site personnel on the correct operation and maintenance, including how to properly adjust the wear ring.



## Service Centers and Rebuilds

To guarantee top-notch products for our customer at every service centers worldwide, all pump assemblies are uniformly constructed with the same precision and quality. These service centers are strategically located around the world, allowing us to provide fast and efficient offsite rebuilds.

## Aftermarket

By working closely with our customers, we ensure that our products are readily available whenever they are needed. From casting to finished painted parts, FLS has the equipment and expertise to deliver the best material options to our customers. Not only that, but our engineers are continually innovating to give our customer the best solutions.

FLS has a wide range of elastomers that can handle various chemicals, pH/concentrations, and temperatures ranges. Additionally, we offer proprietary high chrome irons specially designed to provide outstanding abrasion and/or corrosion resistance. Beyond that, in the most abrasive applications we offer tungsten carbide laser cladding to significantly extend the wear life. New to our material offering is our range of urethane liners capable of operating at higher tip speeds and able to withstand fine particle wear.

## KREBS® Regional Global Sales

### FLSmith Inc.

Tucson Operations  
Tucson, AZ USA  
Tel + 1 520 744 8200  
krebs@flsmith.com

### FLSmith Pty Ltd.

Welshpool  
Western Australia  
Tel: +61 8 6258 4800  
krebsaustralia@flsmith.com

### FLSmith - South Africa

Stormill, Randburg  
South Africa  
Tel: +27 0 10 210 4750  
krebsafrica@flsmith.com

### KREBS® product offerings for Mining and Industrial

- KREBS® Slurry pumps
- KREBS® Cyclones
- KREBS® Knife Gate Valves
- KREBS® DeSanders
- KREBS® Vessels

### FLSmith GmbH Austria

Neusiedl am See, Austria  
Tel: +43 2167 3345  
krebs europe@flsmith.com

### FLSmith - Chile

Santiago, Chile  
Tel: +56 2 2463 8350  
krebschile@flsmith.com

**Follow us here**



[flsmidth.com/linkedin](https://flsmidth.com/linkedin)



[flsmidth.com/twitter](https://flsmidth.com/twitter)



[flsmidth.com/facebook](https://flsmidth.com/facebook)



[flsmidth.com/instagram](https://flsmidth.com/instagram)



[flsmidth.com/youtube](https://flsmidth.com/youtube)

**Contact us**

**FLSmidth A/S**

2500 Valby  
Denmark  
Tel. +45 36 18 10 00  
Fax +45 36 30 18 20  
[info@flsmidth.com](mailto:info@flsmidth.com)

**FLSmidth Inc.**

Tucson Operations  
Tucson, AZ 85743  
USA  
Tel + 1 520-744-8200  
[krebs@flsmidth.com](mailto:krebs@flsmidth.com)



[flsmidth.eco/contact](https://flsmidth.eco/contact)

Copyright © 2024 FLSmidth A/S.  
All Rights Reserved. FLSmidth and FLS  
are (registered) trademarks of  
FLSmidth A/S. This brochure makes no  
offers, representations or warranties of  
any kind (express or implied), and  
information and data contained in this  
brochure are for general reference  
only and may change at any time.  
FLSmidth does not guarantee or make  
any representation regarding the use  
or the results of the information or the  
data provided in the brochure in terms  
of its correctness, accuracy, reliability  
or otherwise, and shall not be liable for  
any loss or damage of any kind  
incurred as a result of the use of the  
information or data provided in the  
brochure.