

# KREBS® vMAX™ Vertical cantilever pump



**FLS**

# Set it and forget it

## A sump pump you can trust

We developed our vMAX™ line of vertical cantilever pumps for both conventional and harsh sump and process duties that require reduced degradation of any pumped solids. The fully recessed impeller design permits passing of large solids and operation without the need for sump level control. The vMAX™ design provides reliable continuous operation, no required impeller adjustments, less downtime, and simple maintenance.

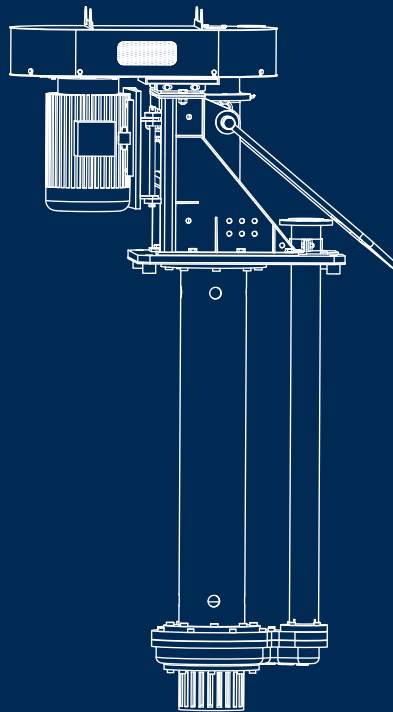

### Benefits

- Large solids passing size
- Extended wear life
- No sump level control required
- Easy to operate, easy to maintain
- No agitator required

# vMAX™ Pumps

## Making sump and plant floor clean-up a breeze!

The process of pumping fluids that contain large solids or transferring highly viscous fluids can be fraught with difficulties. Common problems with vertical sump pumps include the build-up of solids at the suction inlet, leakage from the back of the casing, and excessive vibration.

With an advanced hydraulic design, our vMAX™ pump tackles these common problems making sump and plant floor clean-up a breeze!

The vMAX™ pump's oversized suction-strainer works like a particulate filter to prevent solids from bidding or clogging the suction inlet. This increases operational life and eliminates the need to remove the pump for cleaning. The improved impeller design eliminates the vibration issues, while its high-performance expelling vanes on the back of the impeller shroud work to prevent leakage.

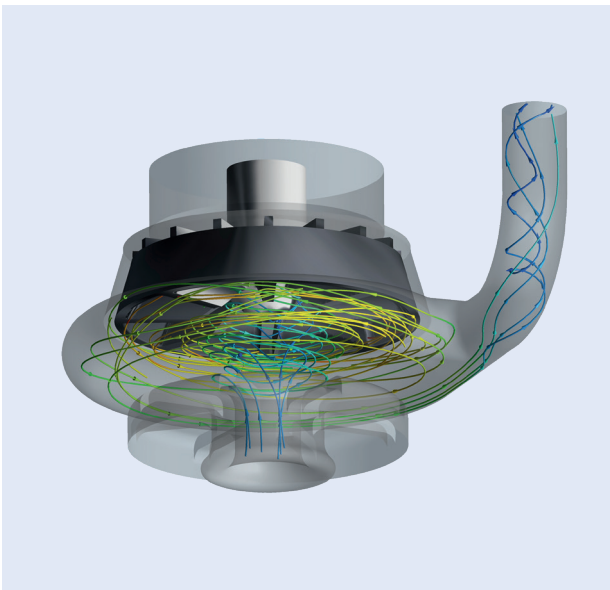

Computational Fluid Dynamic (CFD) modeling of vortex effect created by the vMAX™ impeller.

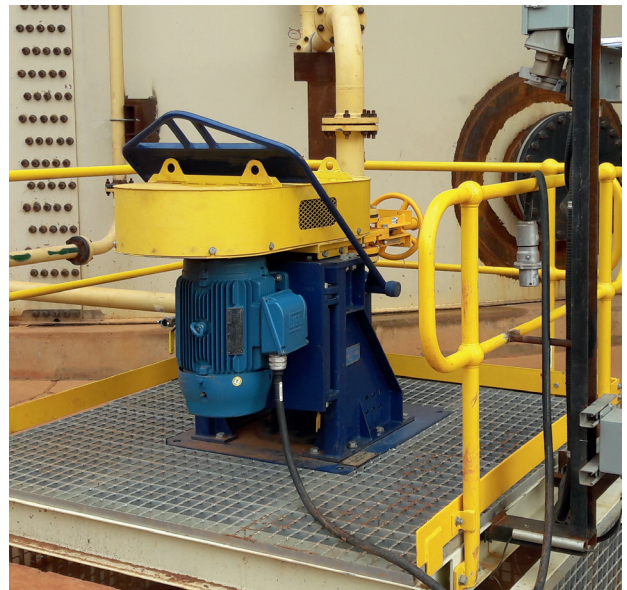

vMAX™ installation with a standard motor mount configuration. Other configurations are available.

# vMAX™

## Metal Vertical Pump

Our vMAX™ line of vertical hard-metal pumps provide reliable operation even in the most extreme conditions. The vMAX™ prevents solids from settling in the sump and delivers continuous operation without sump level control.

**You truly can install it, set it, and forget it.**

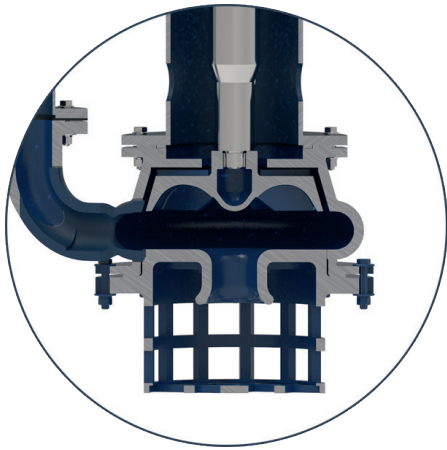

Designed to operate successfully under typical-to-extreme sump pump duties, the vMAX™ delivers the following:

### **Prevents solids from settling in the sump**

An agitator is not necessary to prevent solids from settling in the sump. The vortex effect created by the vMAX™ pump's impeller creates enough turbulence to keep the solids in suspension and the sump free of sediment build-up.

### **No sump level control required**

In conventional designs, when the sump level falls below the suction, the pump loses its prime and the slurry comes rushing back down the discharge pipe. Returning slurry impacts the rotating impeller and cause violent vibrations which can lead to catastrophic failure.

With this problem in mind, we designed the vMAX™ pump to include a fully recessed impeller. When the sump has been emptied of slurry, the recessed impeller allows the slurry to return safely down the discharge pipe without contacting the impeller.

The result? The vMAX™ operates without the need for sump level control.

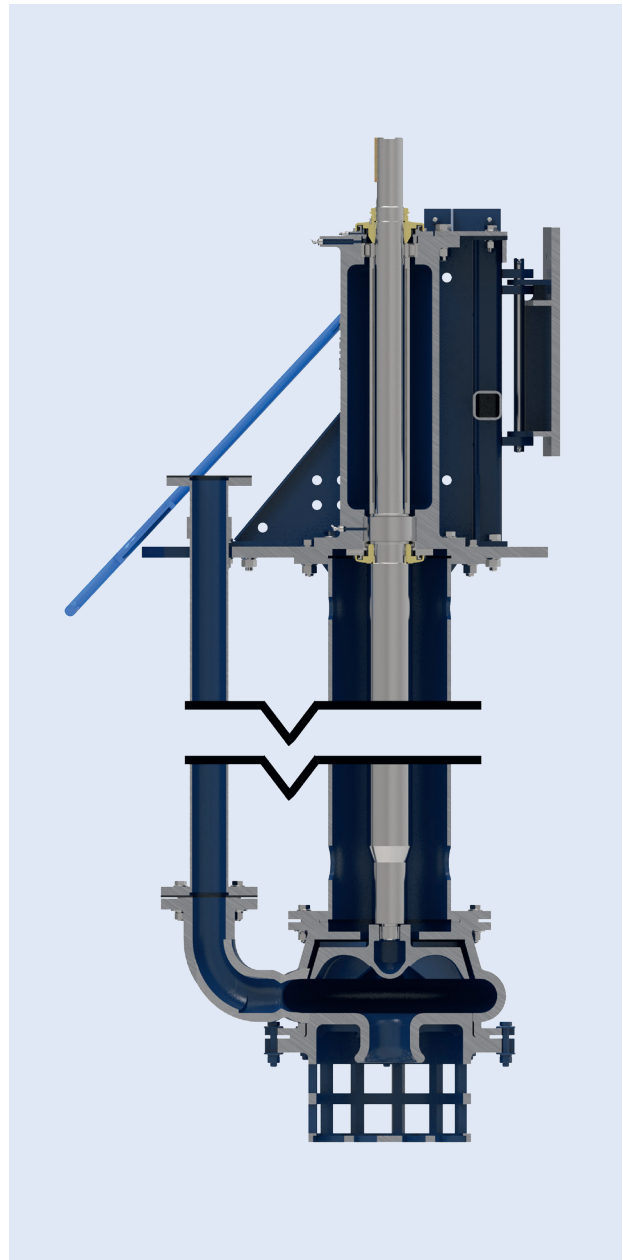



# vMAX™-R Rubber Lined Vertical Pump

The vMAX™-R rubber lined cantilever pump has been developed for the most difficult corrosive applications. Every part that could come into contact with the slurry is elastomer lined to ensure reliability. With multiple materials options, the vMAX™-R is adaptable to many different acid and slurry temperature combinations.

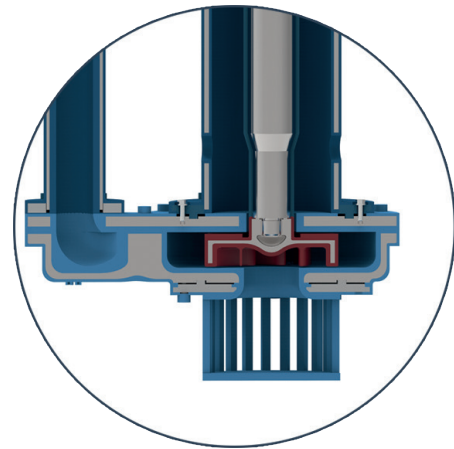
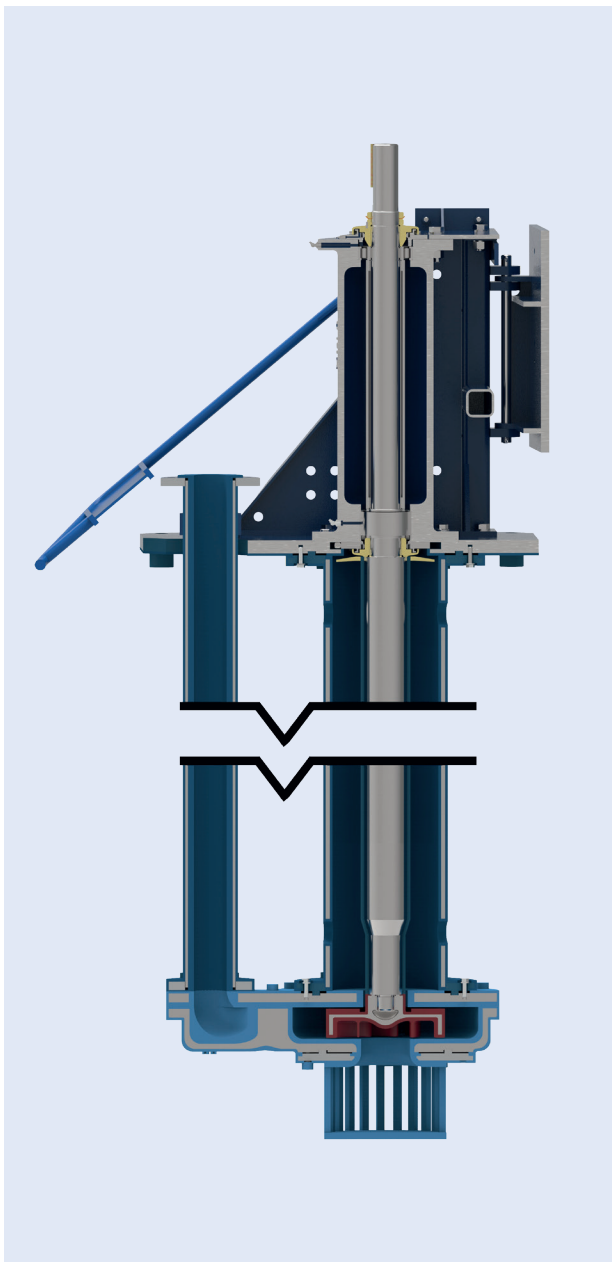

Available in a range of corrosion resistant materials such as natural rubber, neoprene, EPDM, and chlorobutyl.

## Extended wear life

Our vMAX™ and vMAX™-R pumps provide the best wear life for each sump and process application. The vMAX™-R handles corrosive applications, while the vMAX™ covers conventional and extreme duties - even with highly viscous slurries that contain large solids.

# Reliable pump operation in the most extreme conditions

## Additional features include

**Cantilever design** – Does not require a stuffing box seal or submerged bearings.

**Drive-end bearing** – Is a fixed-clearance twin taper roller that provides axial thrust. The impeller-end bearing is a parallel roller design that delivers radial thrust. Bearings are grease-lubricated. A rigid 1040 steel shaft with large bearing span reduces shaft deflection and bearing loads.

**Integral discharge elbow** – On the casing works to reduce localized wear.

**Integral mounting plate** – For supporting the pump above the sump, a steel discharge pipe extends above the liquid level, and is fixed to the mounting plate for access to your existing piping.

**Adjustable motor mount** – Is integral to the power frame assembly, and allows tension adjustment of the v-belt drive.

**Lifting yoke** – For crane hook suspension over the sump.

## vMAX™ and vMAX™-R size range

Imperial units (in)	Metric units (mm)
2 x2	50 mm x 50 mm
3 x3	80 mm x 80 mm
4 x4	100 mm x 100 mm
6 x6	150 mm x 150 mm
8 x8	200 mm x 200 mm

Standard setting lengths 1.2m-3.0m. For non-standard setting lengths consult FLS representative.

## vMAX™ Product applications

- Mining and mineral processing
- Carbon transfer
- Industrial processing
- Heavy-duty abrasive slurries
- Power Plants
- Dewatering
- Plant floor cleanup
- Low PH applications (vMAX™-R)
- Chemical processing (vMAX™-R)

## KREBS® Regional Global Sales

**FLSmidth Inc.**  
Tucson Operations  
Tucson, AZ USA  
Tel +1 520 744 8200  
krebs@flsmidth.com

**FLSmidth Pty Ltd.**  
Welshpool  
Western Australia  
Tel: +61 8 6258 4800  
krebssaustralia@flsmidth.com

**FLSmidth - South Africa**  
Stormill, Randburg  
South Africa  
Tel: +27 0 10 210 4750  
krebssafrica@flsmidth.com

### KREBS® product offerings for Mining and Industrial

- KREBS® Slurry pumps
- KREBS® Cyclones
- KREBS® Knife Gate Valves
- KREBS® DeSanders
- KREBS® Vessels

**FLSmidth GmbH Austria**  
Neusiedl am See, Austria  
Tel: +43 2167 3345  
krebseurope@flsmidth.com

**FLSmidth - Chile**  
Santiago, Chile  
Tel: +56 2 2463 8350  
krebsschile@flsmidth.com

# FLS provides full life-cycle service for all our slurry pumps

## Pump Selection

Selection of the appropriate pump for a specific application is the work of an expert, as is the proper operation and maintenance of the pump when installed and in service. FLS offers this industry-leading pump expertise, assisting in selecting the most suitable pumps for our customer's specific application needs.

## Aftermarket

By working closely with our customers, we ensure that our products are readily available whenever they are needed. From casting to finished painted parts, FLS has the equipment and expertise to deliver the best material options to our customers. Not only that, but our engineers are continually innovating to give our customer the best solutions.

FLS has a wide range of elastomers that can handle various chemicals, pH/concentrations, and temperatures ranges. Additionally, we offer proprietary high chrome irons specially designed to provide outstanding abrasion and/or corrosion resistance. Beyond that, in the most abrasive applications we offer tungsten carbide laser cladding to significantly extend the wear life. New to our material offering is our range of urethane liners capable of operating at higher tip speeds and able to withstand fine particle wear.

## Service Centers and Rebuilds

To guarantee top-notch products for our customer at every service centers worldwide, all pump assemblies are uniformly constructed with the same precision and quality. These service centers are strategically located around the world, allowing us to provide fast and efficient offsite rebuilds.

## Site Support

Once the pump is installed, our team of site support engineers closely monitors the pump's operation on-site, ensuring that it is consistently operating within the designated parameters. This is particularly important as mines and mineral processing plants are not static operations: they develop and change over time, which can result in pumps operating outside of their BEP zone, with negative impacts on performance, energy consumption, and wear rates.

A site support engineer will note any changes to the operating conditions and be able to recommend upgrades or changes to practice that will ensure the pump continues to deliver the best possible performance. They can also offer training to mine personnel on the correct operation and maintenance, including how to properly adjust the wear ring.

## Full Service Lab Testing

Our full-service lab provides performance testing and customer specific testing. The knowledge gained from the test work and slurry analysis help lay the foundation for successful projects. We also utilize this facility for product development test work to ensure we are always providing our customers with the highest quality and cutting-edge technology.



**Follow us here**



[flsmidth.com/linkedin](https://flsmidth.com/linkedin)



[flsmidth.com/twitter](https://flsmidth.com/twitter)



[flsmidth.com/facebook](https://flsmidth.com/facebook)



[flsmidth.com/instagram](https://flsmidth.com/instagram)



[flsmidth.com/youtube](https://flsmidth.com/youtube)

**Contact us**

**FLSmidth A/S**

2500 Valby  
Denmark  
Tel. +45 36 18 10 00  
[info@flsmidth.com](mailto:info@flsmidth.com)

**FLSmidth Inc.**

Tucson Operations  
Tucson, AZ 85743  
USA  
Tel + 1 520-744-8200  
[krebs@flsmidth.com](mailto:krebs@flsmidth.com)



[flsmidth.eco/contact](https://flsmidth.eco/contact)

Copyright © 2024 FLSmidth A/S. All Rights Reserved. FLSmidth and FLS are (registered) trademarks of FLSmidth A/S. This brochure makes no offers, representations or warranties of any kind (express or implied), and information and data contained in this brochure are for general reference only and may change at any time. FLSmidth does not guarantee or make any representation regarding the use or the results of the information or the data provided in the brochure in terms of its correctness, accuracy, reliability or otherwise, and shall not be liable for any loss or damage of any kind incurred as a result of the use of the information or data provided in the brochure.