

# KREBS® gravelMAX™ pump Designed for abrasive slurries with large solids

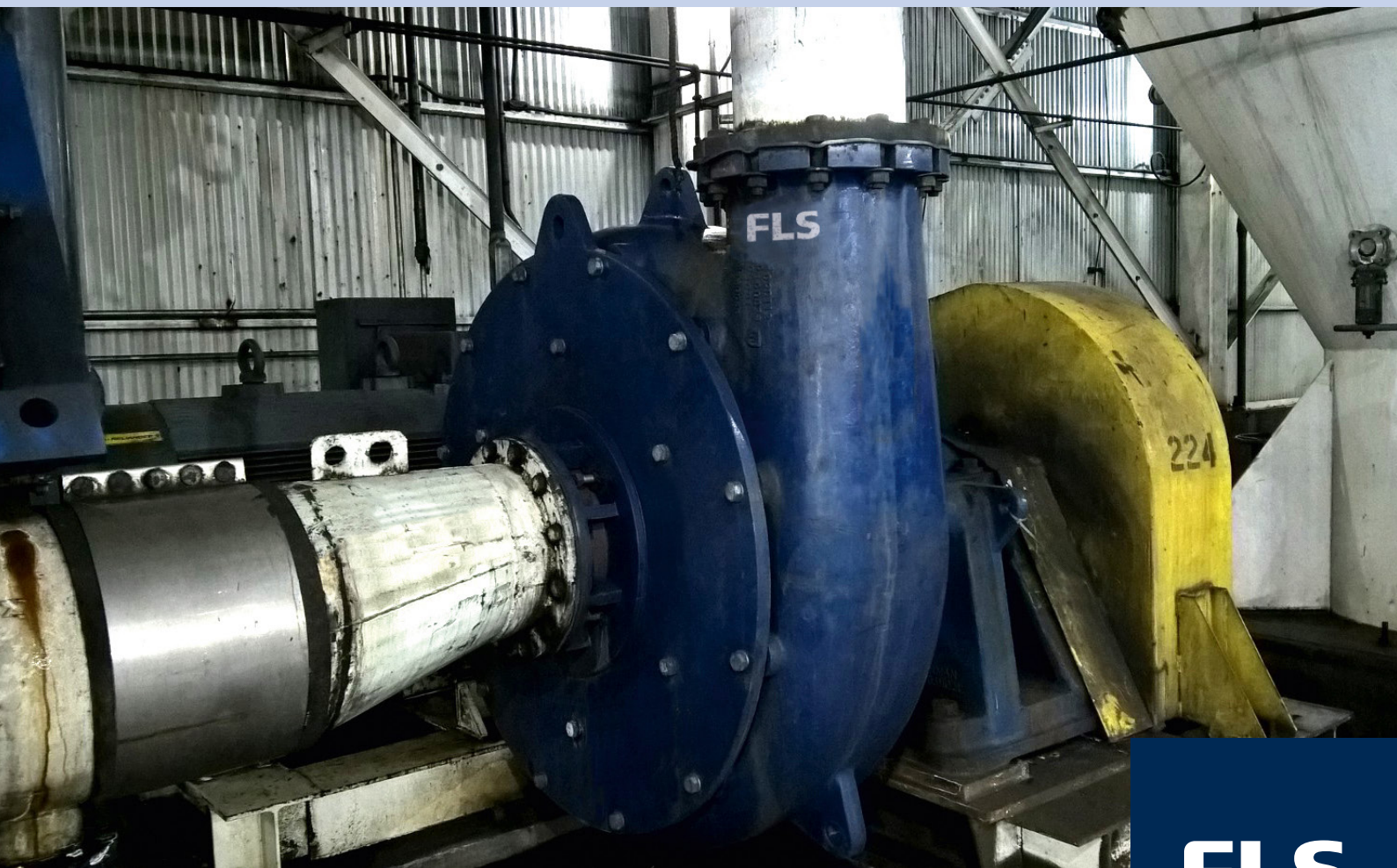

**FLS**

# Efficient pumping in aggressive applications

Why sacrifice wear life to pump the largest solids and most abrasive slurries? This is the question we asked which led to the development of our heavy-duty gravelMAX™ pump. With large internal clearances and a wide impeller, our gravelMAX™ presents the ideal solution to optimise passing size, efficiency and wear life.

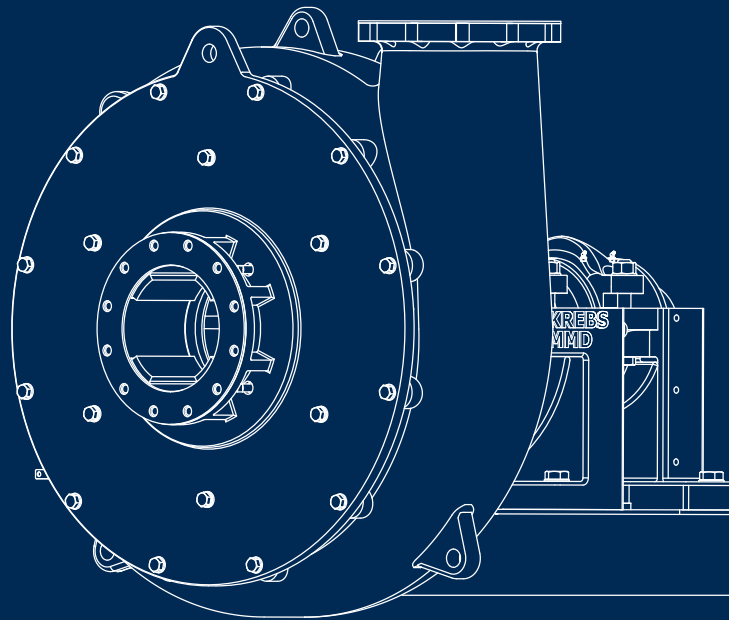

## Key benefits

- Increased wear life
- Pumps large and abrasive solids
- Pulls a higher vacuum
- Reduces cost per ton

# gravelMAX™ benefits of our optimized design

Many slurry pump applications in coal, dredging and hard rock mining require the ability to pump large solids. Traditionally, operations used open impellers or extremely oversized pumps to get the job done – at the cost of ineffective performance. Our gravelMAX™ is designed for high efficiency, and long wear life and tackles the most abrasive slurries.

## Increased wear life

Our unique suction side sealing design – the wear ring – solves both the grinding and recirculation problems within the pump by maintaining clearances between the impeller and the suction side. By maintaining the design performance without increasing the speed, the wear ring feature extends the life of all wet end parts and reduces the power consumption.

## Pumps large and abrasive solids

A wide diameter impeller and increased cutwater clearance allows for the passing of large solids. The addition of the wear ring feature provides a large clearance between the impeller and suction side to ensure solids are not ground up in the pump as they would be with conventional designs.

## gravelMAX™ Pump size / Passing size

Pump size		Maximum passing size	
(in)	(mm)	(in)	(mm)
6 x 4	150	2.75	70
8 x 6	200	5	127
10 x 8	250	6	152
12 x 10	300	7	178
14 x 12	350	8	203

## Pulls a higher vacuum

By eliminating the suction-side recirculation that breaks the vacuum at the eye of the impeller on conventional pumps, the wear ring advantage allows the gravelMAX™ to pump a higher percent solids and higher density solids than any other pump in its class. The ability to pull a higher vacuum makes our gravelMAX™ the ideal pump for the dredging industry.

## Reduces cost per ton pumped

The gravelMAX™ pump's increased clearances, wide diameter impeller and suction-side sealing system work together to offer even and predictable wear rates, less downtime, increased throughput and, ultimately, reduced cost-per-ton pumped.

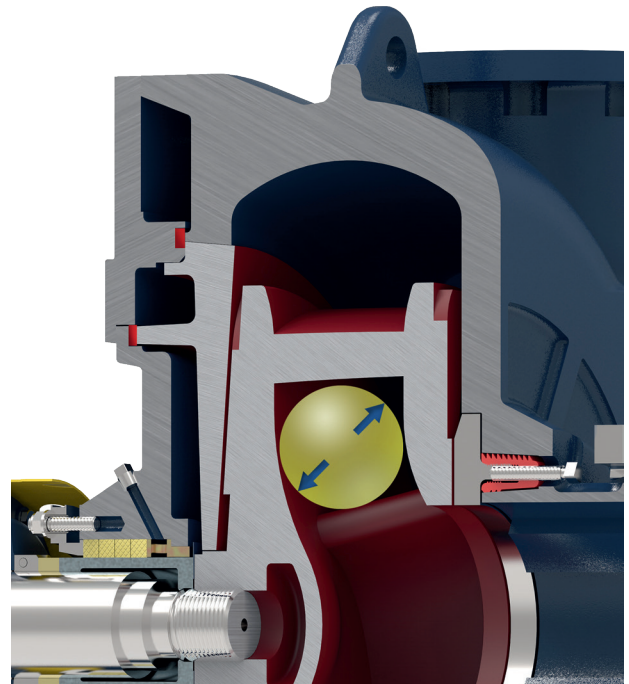



# Design options to maximize solids passing size

## Impeller

- High efficiency impeller customizable to the maximum passing size required

## Casing

- Increased cutwater clearances maximizes solids passing size
- Heavy-duty thick outer casing designed to handle impacts of large and abrasive solids

## Power frame

- Heavy-duty cast iron pedestal with external bearing assembly adjustment mechanism
- Drilled for overhead motor mounting assemblies

## Adjustable wear ring

- Reduces suction-side recirculation
- Adjustable under operation
- Closes clearance at the impeller
- Maintains hydraulic performance
- Bearing assembly movement not required to adjust impeller clearances within the pump

## Reverse-taper roller bearings

- Increase the effective load span to improve life
- Pumping action of taper rollers discharges grease to the outside, preventing ingress of slurry and eliminating possibility of failure due to over-greasing
- Heavy-duty shaft and taper roller bearings rated at 100,000 hours minimum of B10 life



Our gravelMAX™ pump in a heavy media cyclone feed application in coal processing



Our gravelMAX™ pump handles a wide range of solids sizes up to 8" top size.application in coal processing

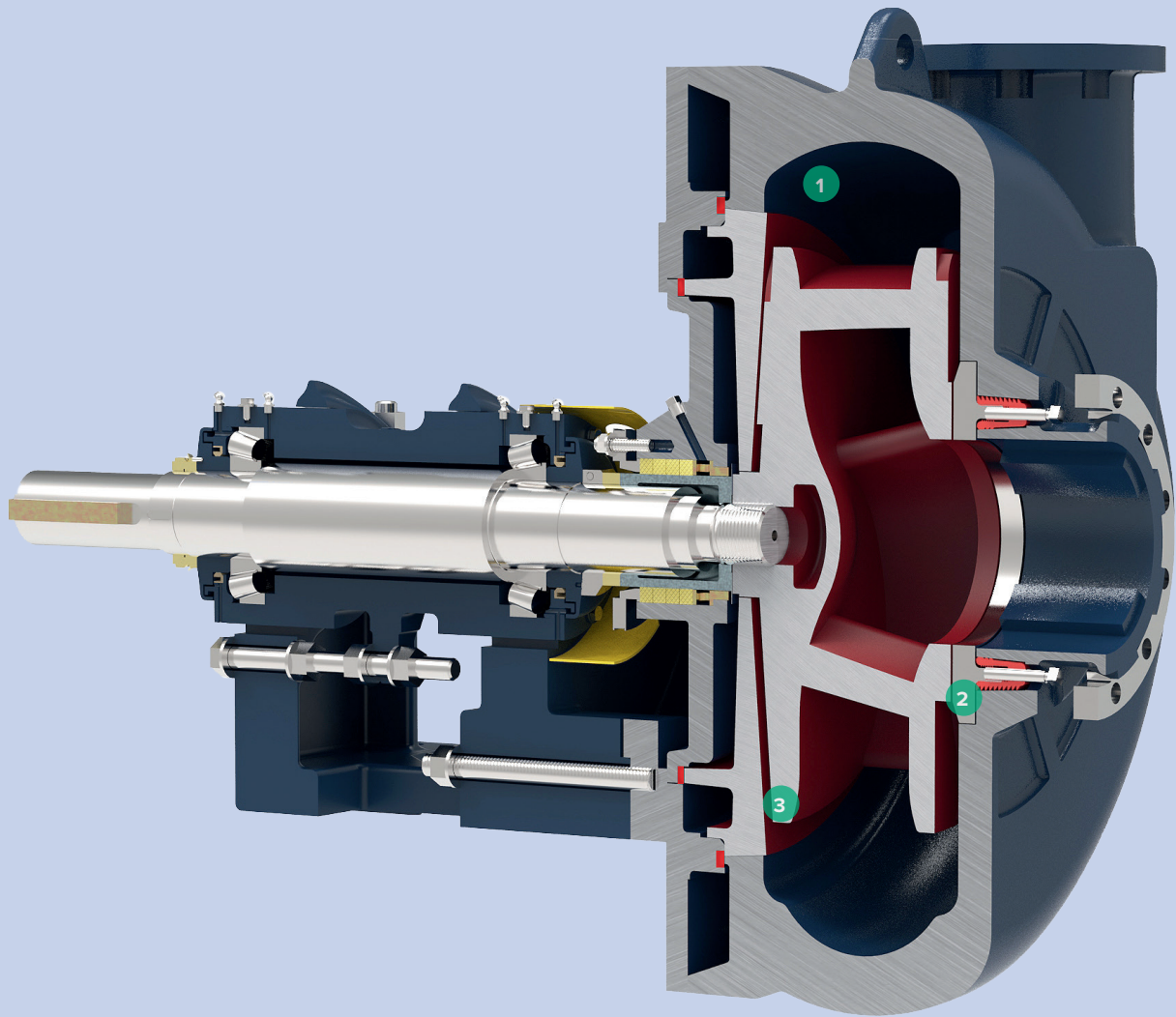

**1. Large clearance**

Increased cutwater clearance for passing large solids and extend the life of the casing

**2. Adjustable Wear Ring**

Closes the suction-side impeller clearance during operation to reduce recirculation and maintain hydraulic performance

**3. Wide diameter impeller**

Our wider diameter impeller increases the maximum passing size

# FLS provides full life-cycle service for all our slurry pumps

## Site Support

Once the pump is installed, our team of site support engineers closely monitors the pump's operation on-site, ensuring that it is consistently operating within the designated parameters. This is particularly important as mines and mineral processing plants are not static operations: they develop and change over time, which can result in pumps operating outside of their BEP zone, with negative impacts on performance, energy consumption, and wear rates.

A site support engineer will note any changes to the operating conditions and be able to recommend upgrades or changes to practice that will ensure the pump continues to deliver the best-possible performance. They can also offer training to mine personnel on the correct operation and maintenance, including how to properly adjust the wear ring.

## Condition Monitoring

FLS offers a variety of digital services including our Site-Connect mobile application and condition monitoring reports. Customer signal/sensor data is connected to FLS Cloud through our Field Agent box or through customer OSI-PI system. Advanced KPI's are then provided through our SiteConnect mobile application. Weekly insight reports look at performance and identify potential failure modes.

## Pump Selection

Selection of the appropriate pump for a specific application is the work of an expert, as is the proper operation and maintenance of the pump when installed and in service. FLS offers this industry-leading pump expertise, assisting in selecting the most suitable pumps for our customer's specific application needs.

## Aftermarket

By working closely with our customers, we ensure that our products are readily available whenever they are needed. From casting to finished painted parts, FLS has the equipment and expertise to deliver the best material options to our customers. Not only that, but our engineers are continually innovating to give our customer the best solutions.

FLS has a wide range of elastomers that can handle various chemicals, pH/concentrations, and temperatures ranges. Additionally, we offer proprietary high chrome irons specially designed to provide outstanding abrasion and/or corrosion resistance. Beyond that, in the most abrasive applications we offer tungsten carbide laser cladding to significantly extend the wear life. New to our material offering is our range of urethane liners capable of operating at higher tip speeds and able to withstand fine particle wear.





# Innovating across industries with world class service

## Full Service Lab Testing

Our full-service lab provides performance testing and customer specific testing. The knowledge gained from the test work and slurry analysis help lay the foundation for successful projects. We also utilize this facility for product development test work to ensure we are always providing our customers with the highest quality and cutting-edge technology.

## Service Centers and Rebuilds

To guarantee top-notch products for our customer at every service centers worldwide, all pump assemblies are uniformly constructed with the same precision and quality. These service centers are strategically located around the world, allowing us to provide fast and efficient offsite rebuilds.

## Installed and serviced in multiple mining applications around the world

- Aggregates (sand plants, cyclone feed, tailings)
- Dredging
- Coal (heavy media cyclone feed)
- Froth
- Heavy-duty abrasive slurries
- Any application requiring large solids passing



## KREBS® Regional Global Sales

### FLSmidth Inc.

Tucson Operations  
Tucson, AZ USA  
Tel: +1 520 744 8200  
krebs@flsmidth.com

### FLSmidth Pty Ltd.

Welshpool  
Western Australia  
Tel: +61 8 6258 4800  
krebsaustralia@flsmidth.com

### FLSmidth - South Africa

Stormill, Randburg  
South Africa  
Tel: +27 0 10 210 4750  
krebsafrica@flsmidth.com

### KREBS® product offerings for Mining and Industrial

- KREBS® Slurry pumps
- KREBS® Cyclones
- KREBS® Knife Gate Valves
- KREBS® DeSanders
- KREBS® Vessels

### FLSmidth GmbH Austria

Neusiedl am See, Austria  
Tel: +43 2167 3345  
krebs europe@flsmidth.com

### FLSmidth - Chile

Santiago, Chile  
Tel: +56 2 2463 8350  
krebschile@flsmidth.com

**Follow us here**



[flsmidth.com/linkedin](https://flsmidth.com/linkedin)



[flsmidth.com/twitter](https://flsmidth.com/twitter)



[flsmidth.com/facebook](https://flsmidth.com/facebook)



[flsmidth.com/instagram](https://flsmidth.com/instagram)



[flsmidth.com/youtube](https://flsmidth.com/youtube)

**Contact us**

**FLSmidth A/S**

2500 Valby  
Denmark  
Tel. +45 36 18 10 00  
[info@flsmidth.com](mailto:info@flsmidth.com)

**FLSmidth Inc.**

Salt Lake City Operations  
Midvale, UT 84047  
USA  
Tel. +1 801 871 7000  
[info.sl.c@flsmidth.com](mailto:info.sl.c@flsmidth.com)



[flsmidth.eco/contact](https://flsmidth.eco/contact)

Copyright © 2024 FLSmidth A/S. All Rights Reserved. FLSmidth and FLS are (registered) trademarks of FLSmidth A/S. This brochure makes no offers, representations or warranties of any kind (express or implied), and information and data contained in this brochure are for general reference only and may change at any time. FLSmidth does not guarantee or make any representation regarding the use or the results of the information or the data provided in the brochure in terms of its correctness, accuracy, reliability or otherwise, and shall not be liable for any loss or damage of any kind incurred as a result of the use of the information or data provided in the brochure.