

# KREBS® Check Valves and Vacuum Breaker Valves



**FLS**

# Our self-actuating valves do the work for you

Isolate the duty or standby pump in your process with our 2-way, check valve. Then use our vacuum breaker valve to protect your pipeline. Our T2 check valves are the most cost effective and efficient answer for mineral processing.

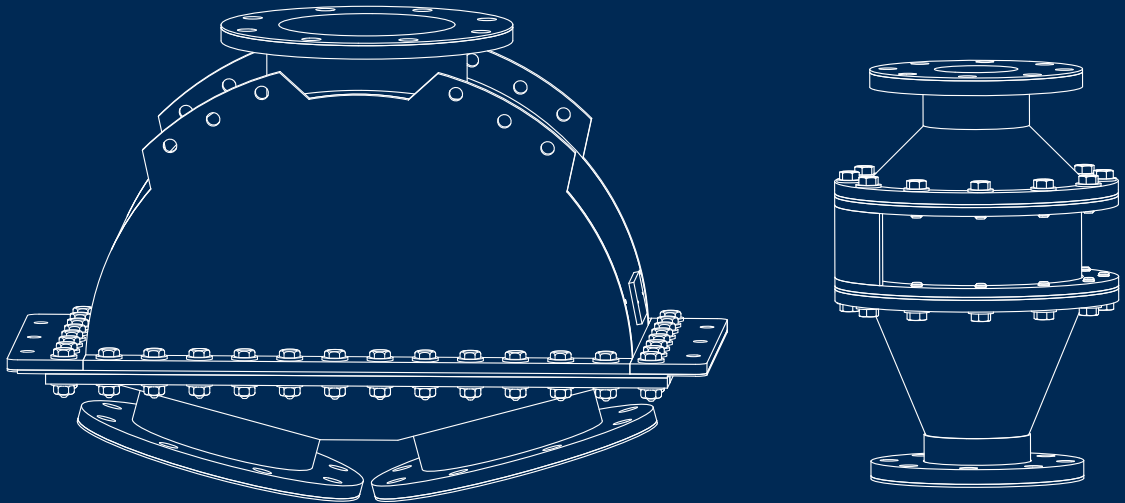

## Key benefits

- Automatic, trouble free operation
- Up to 50% cost reduction
- Protects your pipes

# You just operate the pumps and our T2 check valve directs the slurry!

In a process plant, standby pumps often operate in critical areas. In many instances, two or more pumps discharge into a common line leading to the next step in the process. Prior to the invention of our check valve, this junction required a shutoff valve on each pump discharge line to prevent the fluid from flowing back through the inoperative pump.

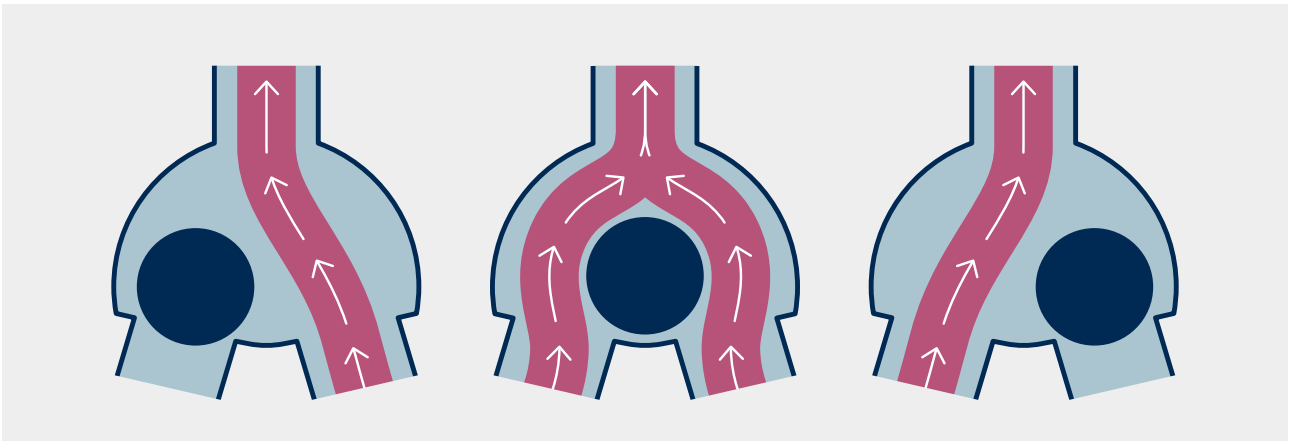

Both pumps can run simultaneously for ease of operation during the changeover

Our T2 Check Valve performs these functions automatically, operating in any position, without any external energy source. It prevents the need for multiple knife gate valves and expensive rubber-lined piping components. The body of the valve replaces the “Y” fitting formerly required for standby pumps, and is designed for maximum abrasion resistance and minimal pressure drop – making it a trouble-free addition to your piping system.

Designed for installation in equipment where there are two pumps operating in parallel, it allows either of the pumps to work individually, as well as simultaneously during the changeover.

## KREBS™ T2 Check Valve

- Invented/developed specifically for heavy duty slurry pump isolation
- Best solution for pump isolation
- Operates in any orientation
- Rugged construction
- Abrasion resistant
- Self-actuating, no air or electricity required

# Automatic simplicity for your standby pump isolation

Our quality, high performance check valve is a self-actuated, two-way, ball-check valve, specifically designed for isolation of standby pumps. Our T2 series is designed for one operating pump and one standby pump and is available as casted or fabricated design.

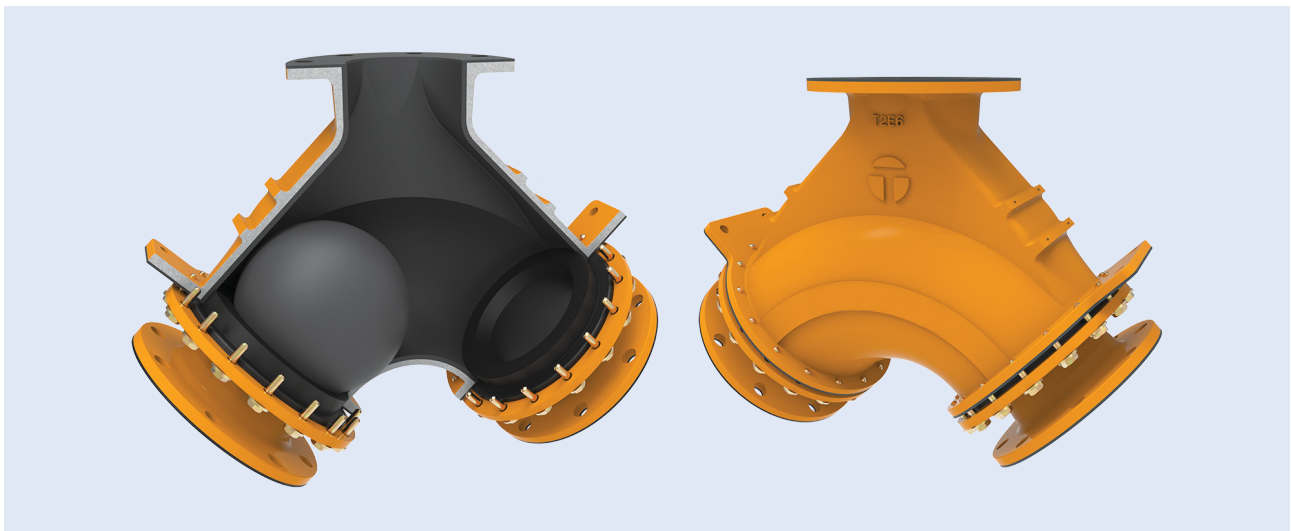

Specifications for cast model	
Size range	3" – 10" (80 mm – 250 mm)
Valve type	Slurry, ball-check
Body style	45° inlet, elastomer lined
Connection style	Flange or victaulic
Temperature range	-60F to 300F (-51c to 149c)
Pressure rating	Up to 150 psi
Body material	Cast ductile iron, 2 coat epoxy painted
Lining material	1/4"(6mm) heavy duty (hot vulcanised) liners include pure gum rubber, high temp EPDM, neoprene, nitrile, and chlorobutyl.
Duty	Heavy duty abrasive applications

## T2 Check Valve Features

- Rugged construction, and proven abrasion-resistant
- Low cost – up to 45% less cost than a traditional two-knife-gate/Y-lateral setup
- Self-actuating – no air or electricity required
- Minimal pressure drop
- Can be supplied with victaulic or flange fittings
- Multiple flange drilling patterns available to meet your specifications
- Field replaceable spare parts available

# Fabricated design is ideal for higher pressure applications

Our fabricated design allows for higher pressure rating up to 600psi and is available in larger sizes for your heavier pumping applications.

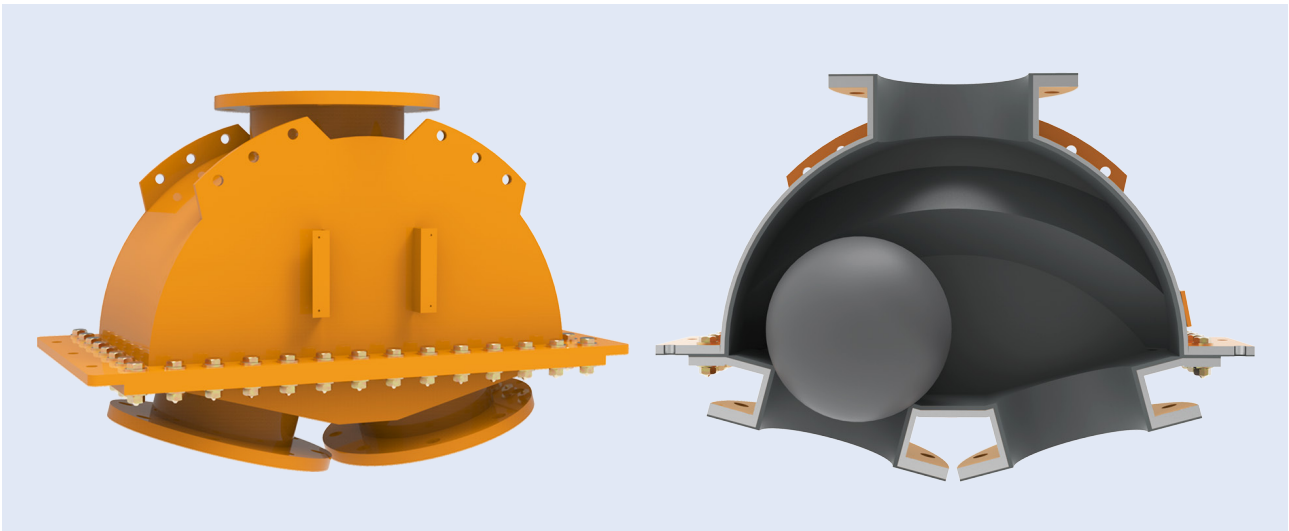

Specifications for fabricated model	
Size range	3" - 30" (80 mm - 750 mm)
Valve type	Slurry, ball-check
Body style	15° inlet, elastomer lined, replaceable seat
Connection style	Flange or victaulic
Temperature range	-60F to 300F (-51c to 149c)
Pressure rating	Up to 600 psi
Body material	Fabricated steel, 2 coat epoxy painted
Lining material	High temp EPDM, neoprene, nitrile, pure gum rubber, and chlorobutyl. Options for heavy duty lining are also available.
Duty	Heavy duty abrasive applications



# Break the vacuum not your pipes

In the event of pump or power failure, you need an automatic solution to break the vacuum created in your pipeline and prevent piping collapse. Our T1 Vacuum Breaker valves, mount on the top of the slurry pipeline.

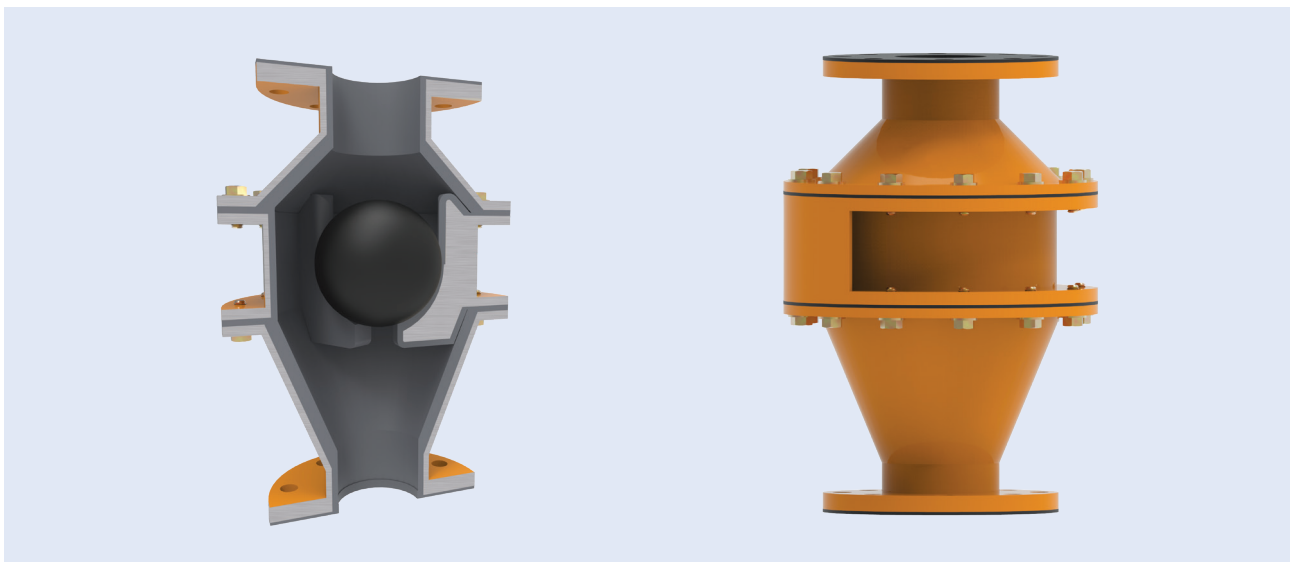

## Protect your pipeline with our Vacuum Breaker valves

**Automatic, trouble-free operation** – Our Vacuum Breaker valve does not require an actuator! In the event of a vacuum condition in your pipeline, it will cause the ball inside the valve to drop, allowing air to enter the pipeline and break the vacuum.

**Simple, low-cost solution** – Operating automatically, our Vacuum Breaker valve is a simple solution for pipeline protection. With no actuators or controls required, it is available at much lower cost than a conventional system.

**Proven and reliability** – The T1 Vacuum Breaker valve has been proven and reliable in mining operations worldwide for over 60 years.

## How it works

With the pipeline in operation, the advancing slurry column increases the positive pressure in the pipeline while the slurry lifts the ball out of its seat effectively sealing off the valve.

Should a pump or power failure cause the slurry pipeline to go down, so it is not in operation, the ball will drop to the bottom of the valve housing, allowing air to enter around it and rush into the pipeline, effectively breaking the vacuum.

Our valve requires no heat tracers for tailings lines. By close coupling the valve to the slurry pipeline, the latent heat in the slurry will prevent freezing. The ball floats in water, so it works even when priming the line.



# Automatic protection from pipeline vacuum situations

Our proven Vacuum Breaker valve is a self-actuated, free ball slurry check valve, specifically designed to break the vacuum created by pump or power failure.

Specifications Vacuum Breaker valve	
Size range	4" (100mm)
Valve type	Vacuum breaker
Body style	Floating ball, elastomer lined
Connection style	Flange or grooved coupling
Temperature range	-60F to 300F (-51c to 149c)
Pressure rating	Up to 600 PSIG 150, 300, 450 and 600 PSIG available
Body material	Fabricated steel, 2 coat epoxy painted
Lining material	Fully lined with multiple elastomer options to suit your specific applications. Materials include: pure gum rubber, chlorobutyl, neoprene, and EPDM.
Duty	Heavy duty abrasive applications

## Our T1 Vacuum Breaker Valve Features:

- Self-operating – no actuator required
- No heat tracers required on tailings lines
- Close coupling the valve to the slurry pipeline allows latent heat in the slurry to prevent freezing
- Unobtrusive – mounts on the top of the slurry pipeline
- Works even under pipeline priming conditions

## KREBS® Regional Global Sales

**FLSmidth Inc.**  
Tucson Operations  
Tucson, AZ USA  
Tel + 1 520 744 8200  
krebs@flsmidth.com

**FLSmidth Pty Ltd.**  
Welshpool  
Western Australia  
Tel: +61 8 6258 4800  
krebssaustralia@flsmidth.com

**FLSmidth - South Africa**  
Stormill, Randburg  
South Africa  
Tel: +27 0 10 210 4750  
krebssafrica@flsmidth.com

### Offres de produits KREBS® pour les mines et l'industrie

- KREBS® Slurry pumps
- KREBS® Cyclones
- KREBS® Knife Gate Valves
- KREBS® DeSanders
- KREBS® Vessels

**FLSmidth GmbH Austria**  
Neusiedl am See, Austria  
Tel: +43 2167 3345  
krebseurope@flsmidth.com

**FLSmidth - Chile**  
Santiago, Chile  
Tel: +56 2 2463 8350  
krebsschile@flsmidth.com

### Follow us here



[flsmidth.com/linkedin](https://flsmidth.com/linkedin)



[flsmidth.com/twitter](https://flsmidth.com/twitter)



[flsmidth.com/facebook](https://flsmidth.com/facebook)



[flsmidth.com/instagram](https://flsmidth.com/instagram)



[flsmidth.com/youtube](https://flsmidth.com/youtube)

### Contact us

#### FLSmidth A/S

2500 Valby  
Denmark  
Tel. +45 36 18 10 00  
[info@flsmidth.com](mailto:info@flsmidth.com)

#### FLSmidth Inc.

Tucson Operations  
Tucson, AZ 85743  
USA  
Tel + 1 520-744-8200  
[krebs@flsmidth.com](mailto:krebs@flsmidth.com)



[flsmidth.eco/contact](https://flsmidth.eco/contact)

Copyright © 2024 FLSmidth A/S. All Rights Reserved. FLSmidth and FLS are (registered) trademarks of FLSmidth A/S. This brochure makes no offers, representations or warranties of any kind (express or implied), and information and data contained in this brochure are for general reference only and may change at any time. FLSmidth does not guarantee or make any representation regarding the use or the results of the information or the data provided in the brochure in terms of its correctness, accuracy, reliability or otherwise, and shall not be liable for any loss or damage of any kind incurred as a result of the use of the information or data provided in the brochure.