

## Product datasheet

# Column Flotation Cell

As an integral part of a flotation circuit, column flotation is highly effective in producing high-quality product, offering superior recovery of fine materials. Through proper column sizing and design, this technology complements mechanical cells and improves overall flotation circuit performance.

Our FLS column flotation technology is rooted in the original EIMCO Pyramid™ brand, with a supply legacy dating back to the 1980s. Our modernised product line offers improved metallurgical performance and modular, customisable designs through our configure-to-order (CTO) program, designed to fit the individual needs of each process.

Our unique column flotation design utilises externally mounted spargers to facilitate bubble particle contacting in a high-shear environment. Through froth washing, our Column Flotation Cells offer advanced performance and consistently produce a high-grade product.

### Key benefits

- Maximised product recovery through ideal hydrodynamic environment
- Improved material grade due to effective froth washing
- High contact with lowest energy input, via innovative sparger system
- Reduced CAPEX costs, shorter delivery times and enhanced circuit functionality through modular CTO design
- Improved froth recovery, reduced utility and pumping demands, from optimised column cell design elements

# FLS

# Column flotation principles

The design elements of column flotation make it unique among flotation techniques; considerations include froth washing effects, froth recovery, residence time, cross-sectional area requirements, aspect ratio and column sparging. Primary contacting occurs among relatively quiescent plug flow conditions within the vessel to promote recovery – specifically for coarser particle sizes. Secondary, external, high intensity contacting promotes bubble-particle collision, which result in attachment rates that optimise fine particle recovery.

Column flotation produces very well-defined, deep and stable froth layers that are washed with the application of percolating water from above, displacing gangue particles such as silicates and carbonates. Thorough washing results in superior final product quality.

The high aspect ratio of the tank creates a quiescent primary contact zone, where plug-flow hydrodynamics under reduced mixing conditions promote the recovery of slower floating minerals.

FLS columns feature venturi-style inline spargers. As the slurry is pumped into the slurry header, it distributes evenly between the spargers.

The air header injects air individually into each sparger.

Air is sheared into the slurry under dynamic pressure changes, providing high-intensity contacting with the bubbles. Compared to traditional jet-nozzle insertion style spargers, this method enhances collision and attachment rates, greatly improving fines recovery.

The externally mounted sparging system, including a recirculation pump and spargers, offers ease of maintenance by eliminating the need to enter the tank. Optional sparger isolation valves allow the spargers to be serviced online.

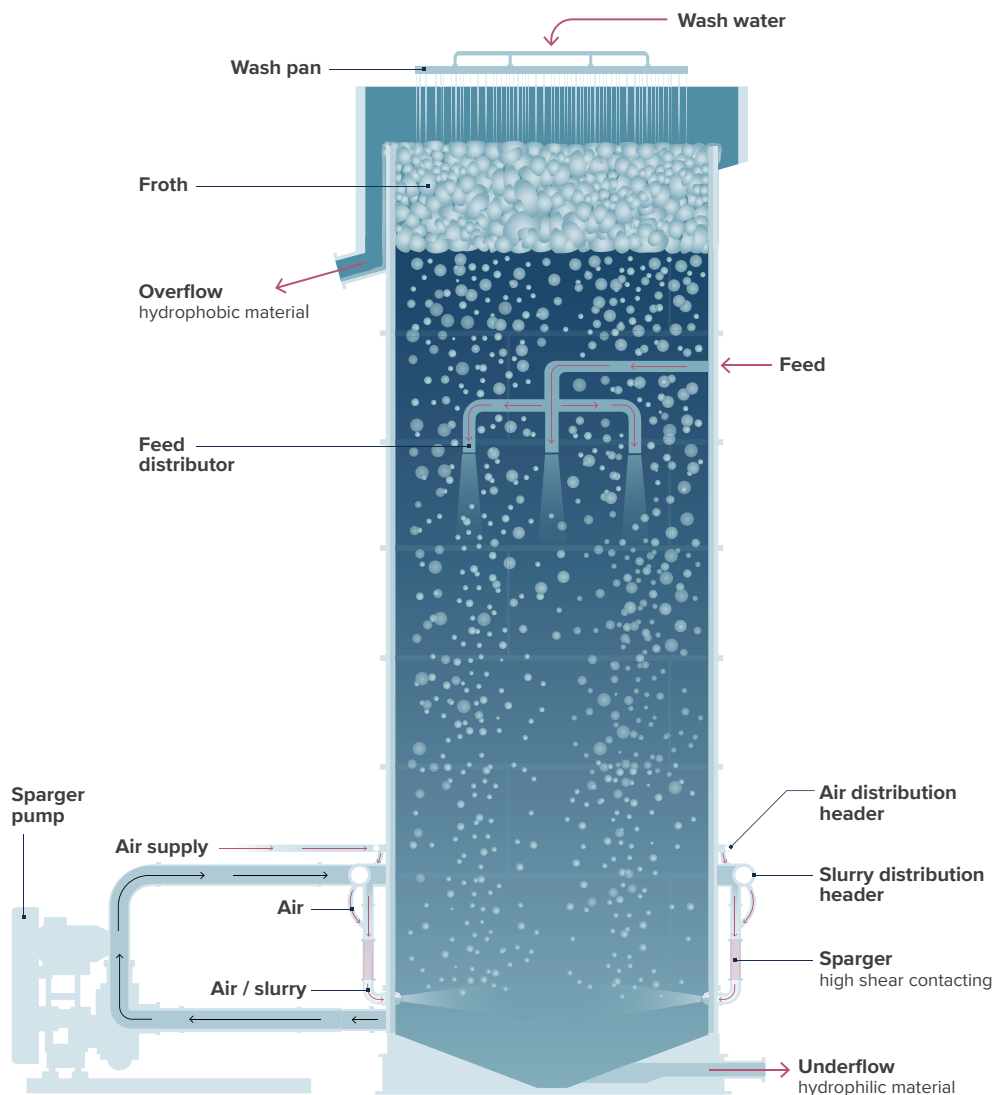

# Sparger innovation: pressure, power, performance

FLS column cells feature external, venturi-style, inline contacting spargers for high-energy contact between air and floatable material. As mixtures of slurry and air pass at high velocity through enlarged- and reduced-area sections of the spargers, they experience pressure shocks. These drastic pressure changes result in flashing of dissolved gases, producing ultrafine bubbles ideally suited to fine particle flotation.

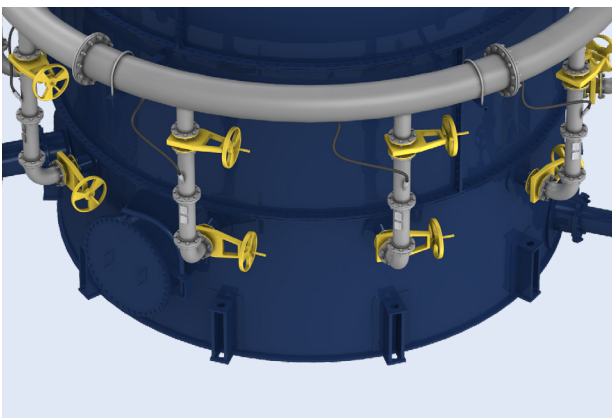

Because flashing is an aggressive hydrodynamic phenomenon with the power to erode metal surfaces, we manufacture our spargers from a composition of highly wear-resistant materials.

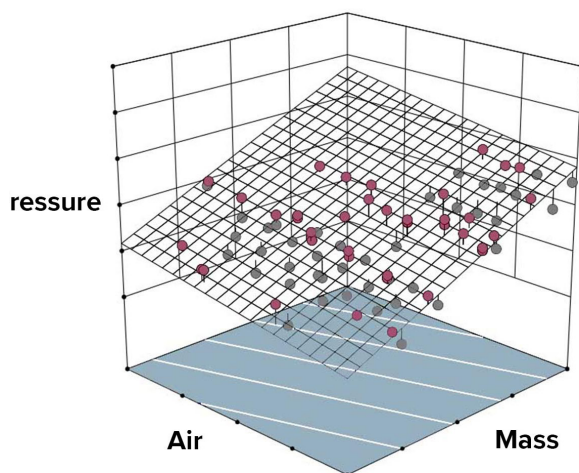

Virtual sparger performance data used in our proprietary sparger system sizing software ensures optimal sparger selection and supply.

Proper sparger and pump selection is as important to column flotation as rotor selection is to mechanical cells. Improper sizing can cause metallurgical shortcomings or excessive energy consumption. Because of this, we have invested in developing comprehensive sizing tools, verified by direct onsite test work and a close partnership with our KREBS® pump division, to deliver a fully integrated flotation solution for your process needs.

All KREBS pump products are designed and manufactured for the highest level of efficiency and quality. The original millMAX™ pump revolutionised the slurry pump industry with its patented “wear ring” suction-side sealing system. This system minimises wear by maintaining suction-side clearances within the pump to reduce internal recirculation and eliminate grinding between the impeller and suction liner. Operators can maintain constant flow, pressure and efficiency as the pump wears, without having to increase the pump speed. Maintaining the pump speed throughout the life of the pump significantly extends the life of all wet-end parts and reduces power consumption. The wear ring feature gained rapid acceptance in the mining industry, enabling us to expand our range of pumps to what it is today. Like all pumps in the KREBS family, the millMAX-e pump includes the wear ring feature in addition to tight internal clearances and a hydraulically advanced impeller, ultimately delivering the most efficient pump for column sparging applications.

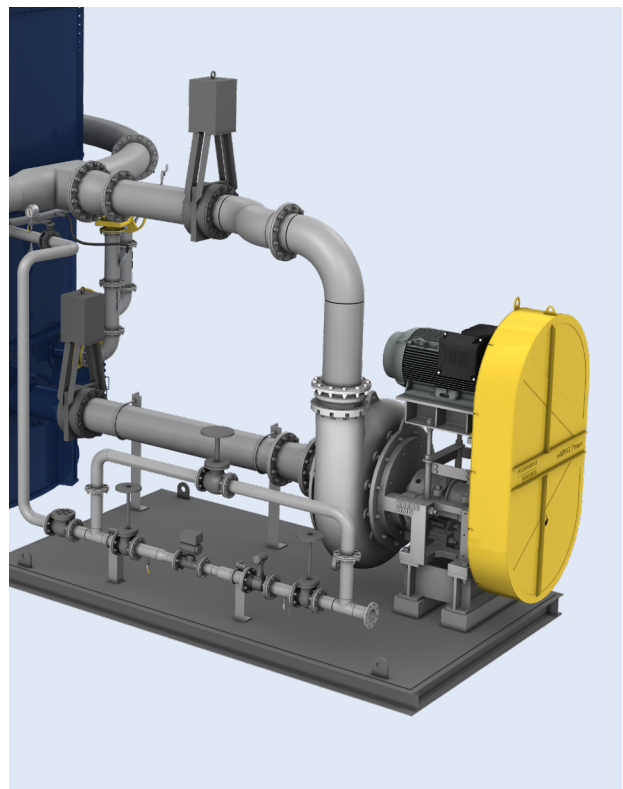

# Effective column sizing and selection

In concert with our other flotation technologies, we offer optimised flotation circuits by selecting the ideal unit operation for your application to produce maximum product at the required grade, while reducing your CAPEX and operational costs.

Achieving superior metallurgical performance requires close attention to proper column sizing and design. Our unique combination of field-proven technology and experienced flotation professionals provides us with fundamental understanding of column cell operation, which, in turn, allows us to effectively size each column and select functional features to ensure proper operation and integration into your flow sheets. This integration can extend as far as inclusion of expert control systems, resulting in enhanced overall flotation circuit operation and performance.





# Configurable standard and configured-to-order (CTO)

We offer flotation columns based on a standardised design criteria, with all design elements optimised and pre-engineered. The selection and supply of equipment on a "configured-to-order" (CTO) basis, rather than an "engineered-to-order" approach, allows for optimised supply costs and expedited delivery timing. Customised products are available where standard offerings are not suitable. Contact an FLS flotation specialist for guidance on the appropriate supply approach.

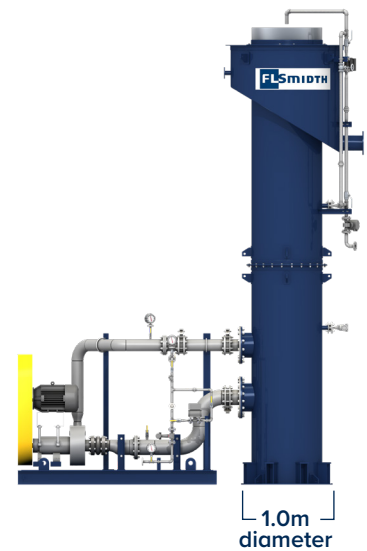

Internal Diameter (m)	Air Demand (Am <sup>3</sup> /h*)		Air Supply Pressure (kPa)	Installed Power (kW)	Feed Capacity (t/h)	Max Wash Water (m <sup>3</sup> /h)	Water Supply Pressure (kPa)
	MIN	MAX					
1	25	45	650	15	5	7	275
1.5	60	95	650	18.5	12	15	275
1.75	75	130	650	22	16	25	275
2	100	170	650	30	21	30	275
2.5	160	265	650	30	33	45	275
2.75	190	320	650	37	40	55	275
3	230	385	650	37	47	65	275
3.5	310	520	650	45	64	85	275
4	400	680	650	75	84	115	275
4.5	510	860	650	75	106	145	275
5	630	1060	650	110	131	175	275
5.5	770	1290	650	110	158	215	275

\*Actual air flow at site conditions

\*Note: Capacities and utility requirements in the table above are based on typical copper cleaner applications. Actual values are application-specific. Contact FLS for precise application information.

**FLSmidth A/S**  
2500 Valby  
Denmark  
Tel. +45 3618 1000  
info@flsmidth.com

**FLSmidth Inc.**  
Salt Lake City Operations  
Midvale, UT 84047-5559  
USA  
Tel. +1 801 871 7000

[www.flsmidth.com](http://www.flsmidth.com)

[info.sl.c@flsmidth.com](mailto:info.sl.c@flsmidth.com)

Copyright © 2024 FLSmidth A/S. All Rights Reserved. FLSmidth and FLS are (registered) trademarks of FLSmidth A/S. This brochure makes no offers, representations or warranties of any kind (express or implied), and information and data contained in this brochure are for general reference only and may change at any time. FLSmidth does not guarantee or make any representation regarding the use or the results of the information or the data provided in the brochure in terms of its correctness, accuracy, reliability or otherwise, and shall not be liable for any loss or damage of any kind incurred as a result of the use of the information or data provided in the brochure.