

ABON® Rollerscreens

High efficiency and low maintenance



FLS

ABON® Rollerscreens maximising your plant productivity

ABON® Rollerscreens offer a low maintenance, high efficiency screening option with a non vibratory, compact, low profile footprint. ABON® Rollerscreens are available in primary, secondary and tertiary options.

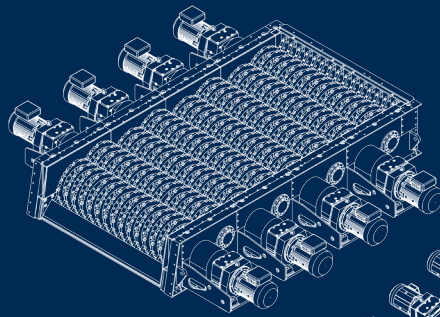

ABON® Primary Rollerscreen

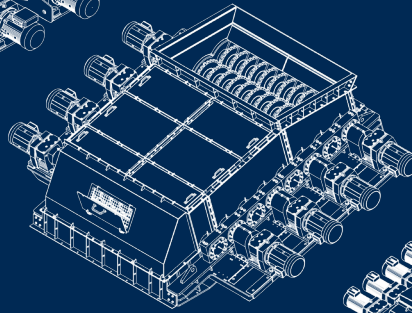

ABON® Secondary Rollerscreen

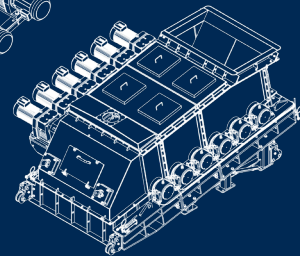

ABON® Tertiary Rollerscreen

Key benefits

- Suitable for low to high feed rates with dry, wet or sticky feed
- Standard or customised options to suit plant needs
- Low vibration Low noise Low dust
- Compact footprint with simple infrastructure
- High efficiency, availability, and productivity

ABON® Rollerscreens – The dependable screening option

High productivity and reliability are fundamental to profitability. Our screens are up to the challenge, giving you high performance, reliability and easy maintenance.

All ABON® Rollerscreens are precision machined and have modular frames, direct drive geared motors and drop in shafts with adjustable screen aperture. We offer dust suppression hoods and undermount scraper cleaning system options.

ABON® Rollerscreen principle

The primary function of the Rollerscreen is to separate undersize from oversize material. Material passes over discs and spacers fitted to the rotating shafts. High agitation ensures separation of the most adherent materials whilst maintaining full flow rates. Coarse material is separated from fine by the aperture set by the disc and spacer gaps.

The screening action minimizes generation of fines. Models are selected by varying roll width and screen length to suit flow rate. A range of product size settings are available by utilising different discs and spacers.

ABON® Rollerscreens process

- Wide range of minerals
- Full ROM feed
- Wet, sticky or dry feeds
- High throughput capabilities

ABON® Rollerscreens process

- Low noise
- Low dynamic forces
- Low vibration
- Adjustable screen aperture settings
- Disc scraper system
- Dust suppression hoods/covers
- Ease of maintenance
- Primary, secondary and tertiary builds

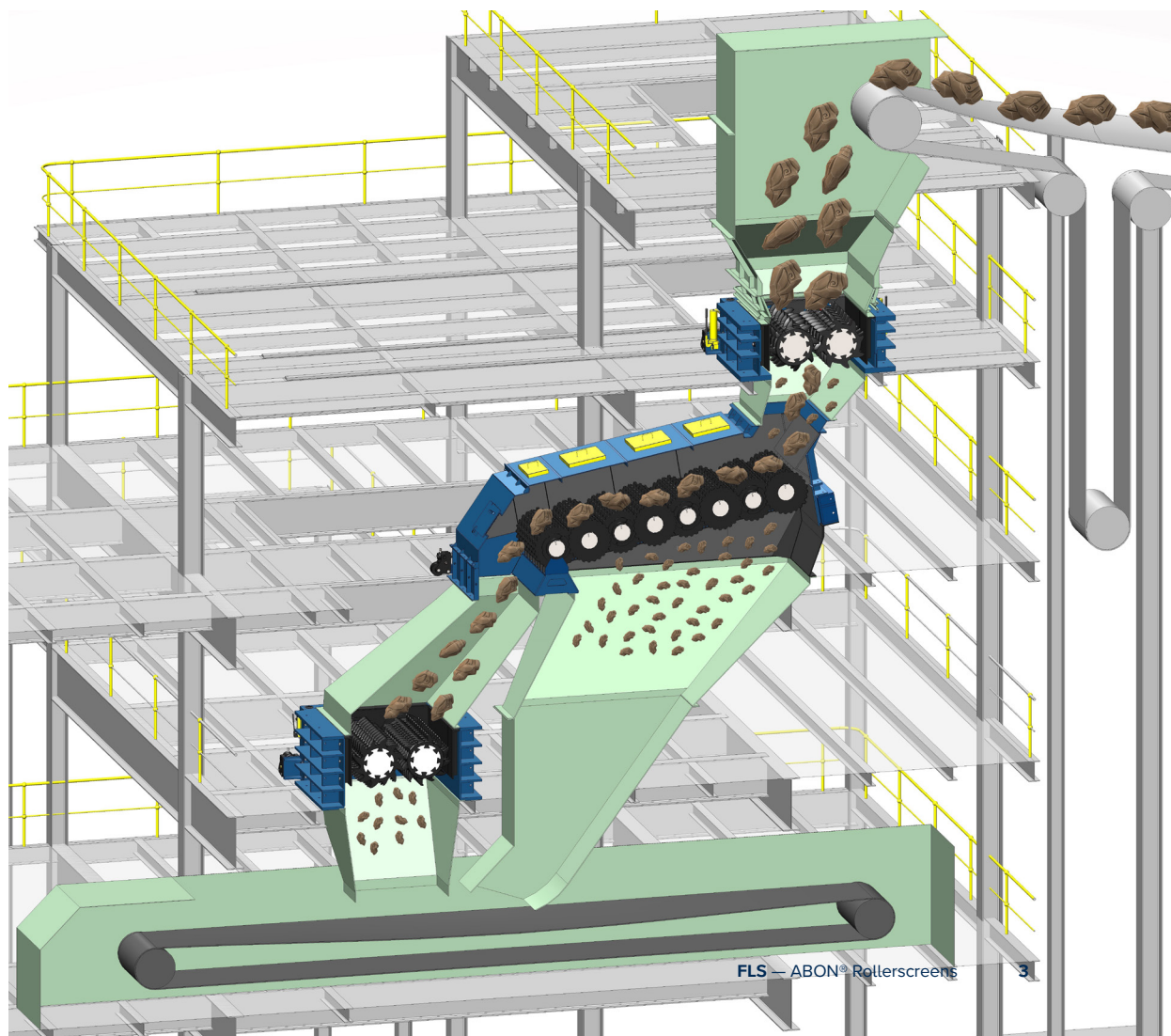

Serviceability by design

Each shaft is directly driven by its own motor and reduction gearbox, eliminating the need for unreliable and complicated belts and chains.

Shafts and drives are quickly and simply removed for maintenance.

Individual keyed discs and spacers allow for a quick change out of worn components or adjustment of the screen apertures.

All bearings are grease lubricated by an automatic lubrication system supplied as standard.

ABON® Rollerscreens can be fitted with fully retractable hydraulically operated wheel assemblies. These wheel assemblies allow units to be easily removed for maintenance.

Wet and Sticky Feeds

Processing wet and sticky feed material is not a problem for an ABON® Rollerscreen.

While our standard disc arrangement helps to promote natural self-cleaning, all ABON Rollerscreens are built with the provision to install a full scraper system if required.



Modular design, for quick and easy maintenance

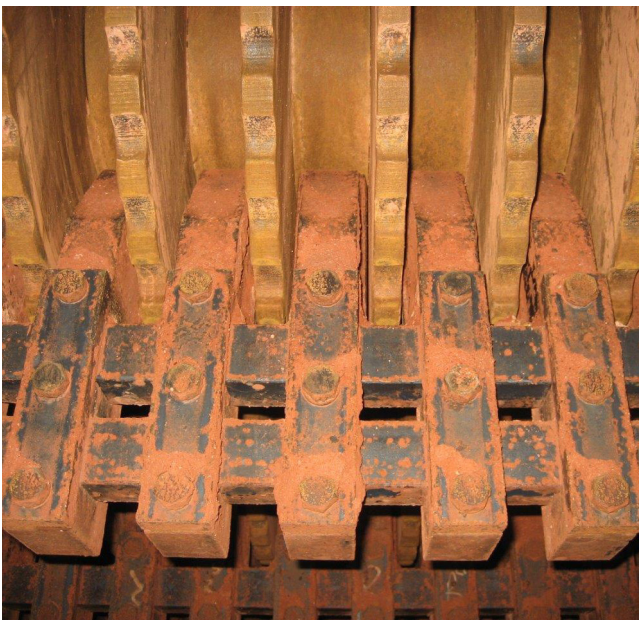

Environmental features

- Low vibration
- Low noise (non-vibratory)
- Minimal water requirements
- Dust suppression hoods/covers
- Recyclable consumables

Integrated scraper system for difficult wet/sticky applications

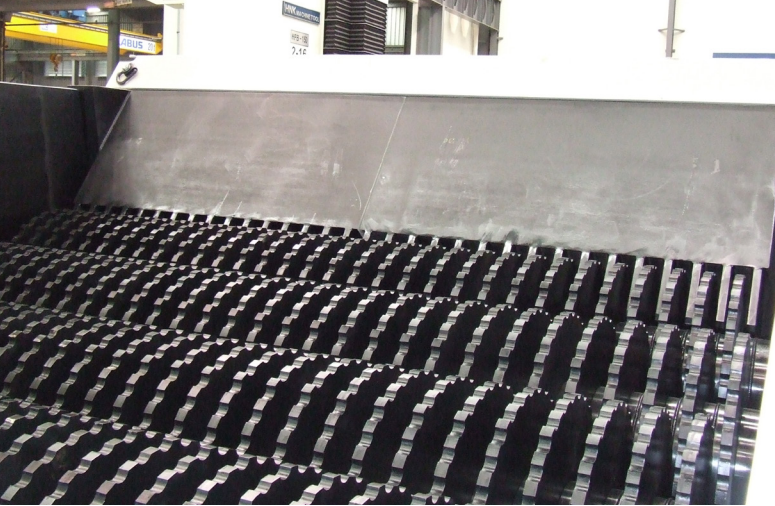

Aftermarket support

As the original equipment manufacturer, we provide a fast turnaround on spare parts. Consumable and rotatable spares are strategically stocked globally. Product experts are based around the world to provide prompt site service and inspections when needed.

Suitable for

- Aluminium industry
- Brickworks
- Copper
- Fertilizer
- Lithium
- Niobium
- Rare earth
- Bauxite
- Cement industry
- Coal
- Iron ore
- Nickel
- Overburden
- Many more

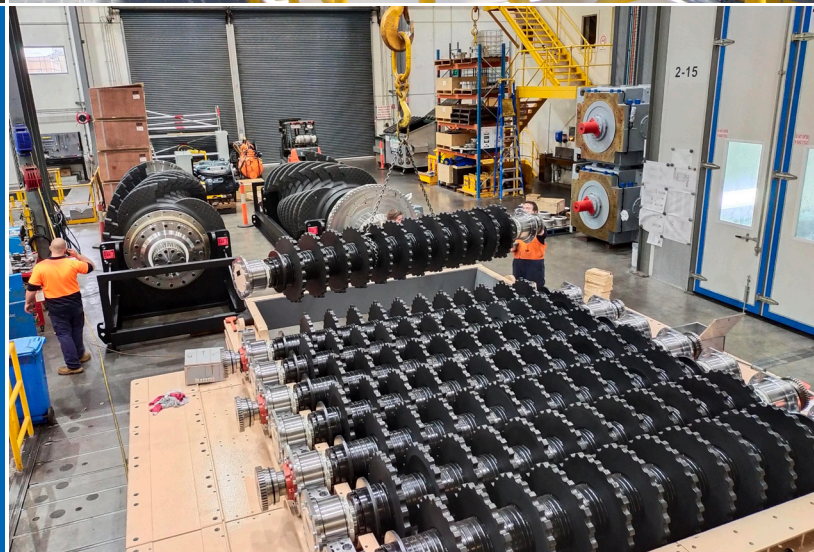

Condition monitoring

Rollerscreens can be fitted with a range of condition monitoring systems to suit your needs

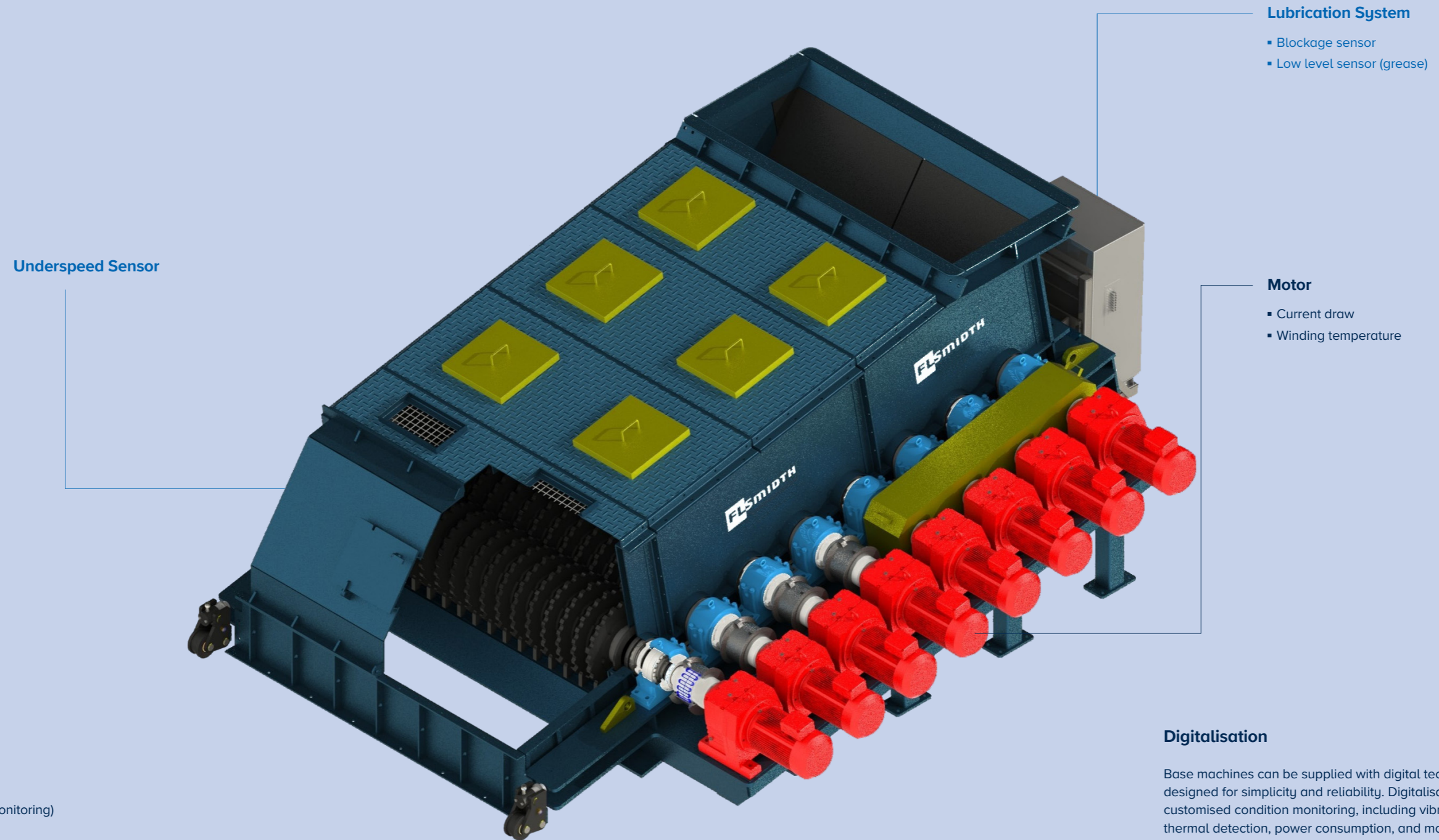

Underspeed Sensor

Lubrication System

- Blockage sensor
- Low level sensor (grease)

Motor

- Current draw
- Winding temperature

Digitalisation

Base machines can be supplied with digital technologies designed for simplicity and reliability. Digitalisation gives you customised condition monitoring, including vibration monitoring, thermal detection, power consumption, and motor speed. Machine control software options can help you advance your operations into the digital era.

- Standard supply
 - Optional extras
- (suitable for online condition monitoring)

ABON® Rollerscreens

Follow us here



flsmidth.com/linkedin



flsmidth.com/twitter



flsmidth.com/facebook



flsmidth.com/instagram



flsmidth.com/youtube

Contact us

FLSmidth A/S

2500 Valby
Denmark
Tel. +45 36 18 10 00
info@flsmidth.com

FLSmidth Pty Ltd

ABON® Sizers and Rollerscreens
Airport West · Victoria 3042
Australia
Tel +61 3 9340 0000
aboninfo@flsmidth.com



flsmidth.eco/contact

Copyright © 2024 FLSmidth A/S.
All Rights Reserved. FLSmidth and FLS are (registered) trademarks of FLSmidth A/S. This brochure makes no offers, representations or warranties of any kind (express or implied), and information and data contained in this brochure are for general reference only and may change at any time. FLSmidth does not guarantee or make any representation regarding the use or the results of the information or the data provided in the brochure in terms of its correctness, accuracy, reliability or otherwise, and shall not be liable for any loss or damage of any kind incurred as a result of the use of the information or data provided in the brochure.